



# Fitting Instructions and Parts List

Part No.  
RTC 7198

Issue 2  
April 1977

**Leyland Cars**  
Service and Parts Division

British Leyland UK Limited  
Jaguar & Rover Triumph, Parts & Accessories  
PO Box 150, Fletchamstead Highway  
Coventry CV4 9DB

**OVERDRIVE**  
**Kit Part No. RTC 8020**  
**for the**  
**LAND-ROVER**  
**Series I, II, IIA and III**  
**with standard gearbox**

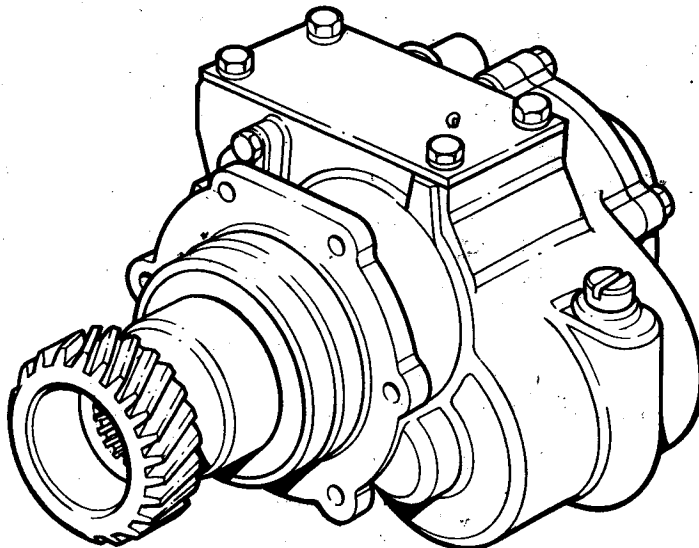

OVERDRIVE UNIT AND SELECTOR MECHANISM

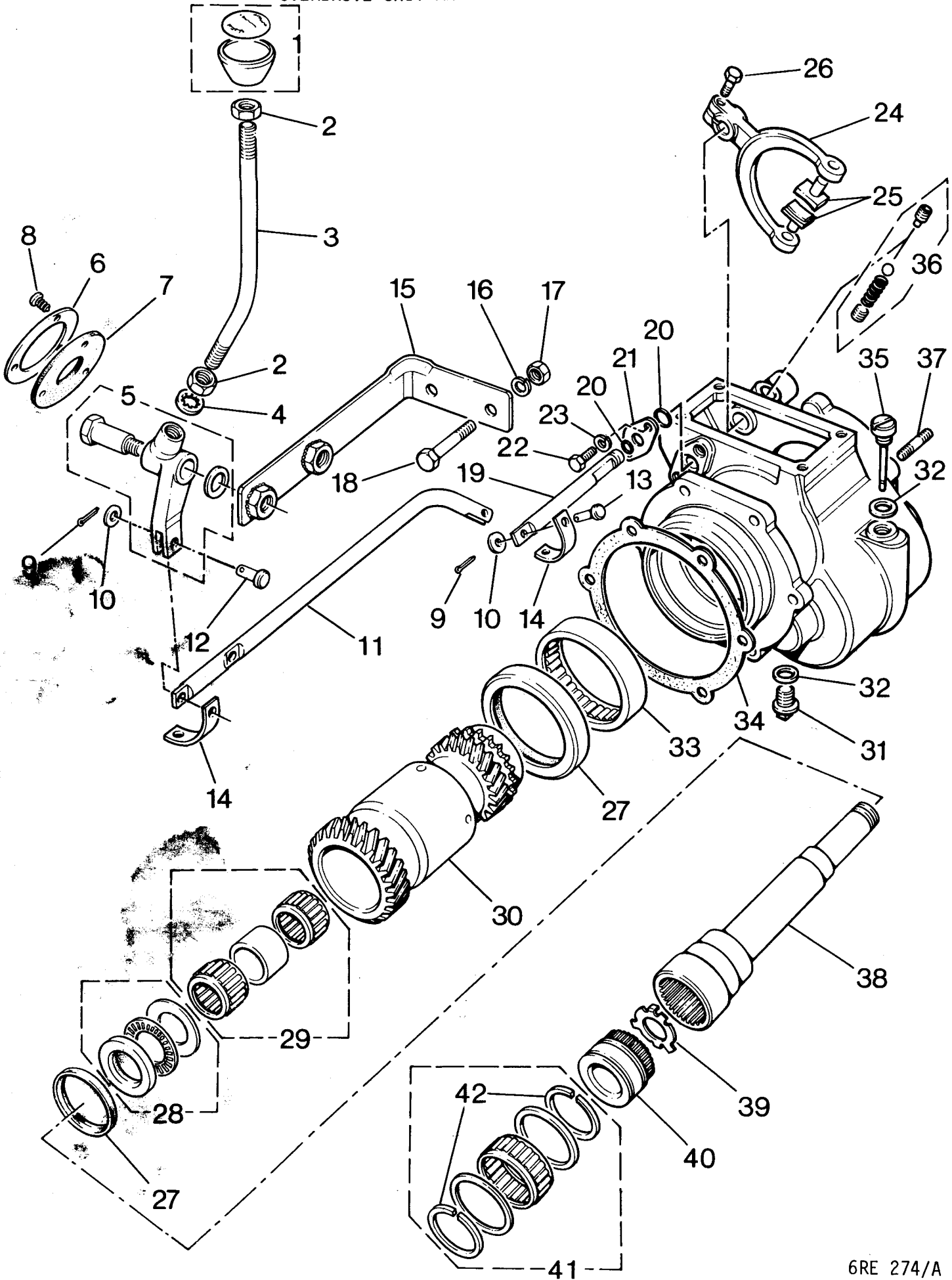

PARTS LIST

Plate Ref	Description	Qty	Part No.
1	Knob for operating lever	1	RTC7158
2	Locknut (M12)	2	NT112041
3	Operating lever	1	RTC7159
4	Shakeproof washer (M12)	1	WF112001
5	Pivot kit	1	RTC7160
6	Sealing plate	1	RTC7196
7	Rubber grommet	1	RTC7195
8	Self-tapping screws	3	534907
9	Split pin (1/16" x 1/2")	2	3958
10	Plain washer (1/4")	2	RTC609
11	Link rod	1	RTC7161
12	Clevis pin, pivot to link rod	1	RTC7162
13	Clevis pin, link rod to selector shaft	1	RTC7163
14	Insulator for clevis pins	2	RTC7197
15	Bracket, supporting pivot	1	RTC7164
16	Spring washer (M8)	2	WM108001
17	Nut (M8)	2	GHF213
18	Bolt (M8 x 50 mm)	2	BH108101
19	Selector shaft	1	RTC7165
20	'O' ring service kit (comprising 4 items)	1	RTC7166
21	Sealing plate for selector shaft	1	RTC7167
22	Screw (M5 x 10 mm)	2	SH105101
23	Spring washer (M5)	2	WL105001
24	Selector fork	1	522001
25	Swivel pads for selector fork	2	532543
26	Pinch bolt (fork to shaft (5/16" UNF x 7/8"))	1	255227
27	Oil seal service kit (comprising 2 items)	1	RTC7173
28	Thrust bearing service kit	1	RTC7174
29	Needle bearing service kit	1	RTC7175
30	Output gearshaft	1	RTC7176
31	Drain plug	1	RTC7177
32	Washer for drain plug or dipstick	2	RTC7178
33	Roller bearing	1	RTC7179
34	Gasket, overdrive to transfer box	1	882047
35	Dipstick	1	RTC7180
36	Detent service kit	1	RTC7181
37	Stud, rear cover to main casing	4	RTC7191
38	Mainshaft	1	RTC7168
39	Lockwasher, securing clutch sleeve	1	RTC7169
40	Clutch sleeve	1	RTC7170
41	Needle bearing service kit	1	RTC7171
42	Circlip service kit (comprising 5 items)	1	RTC7172

Note: Parts not carrying a plate reference are NSS (Not supplied separately).

Encloses parts which form an assembly or kit.

-4-  
OVERDRIVE UNIT

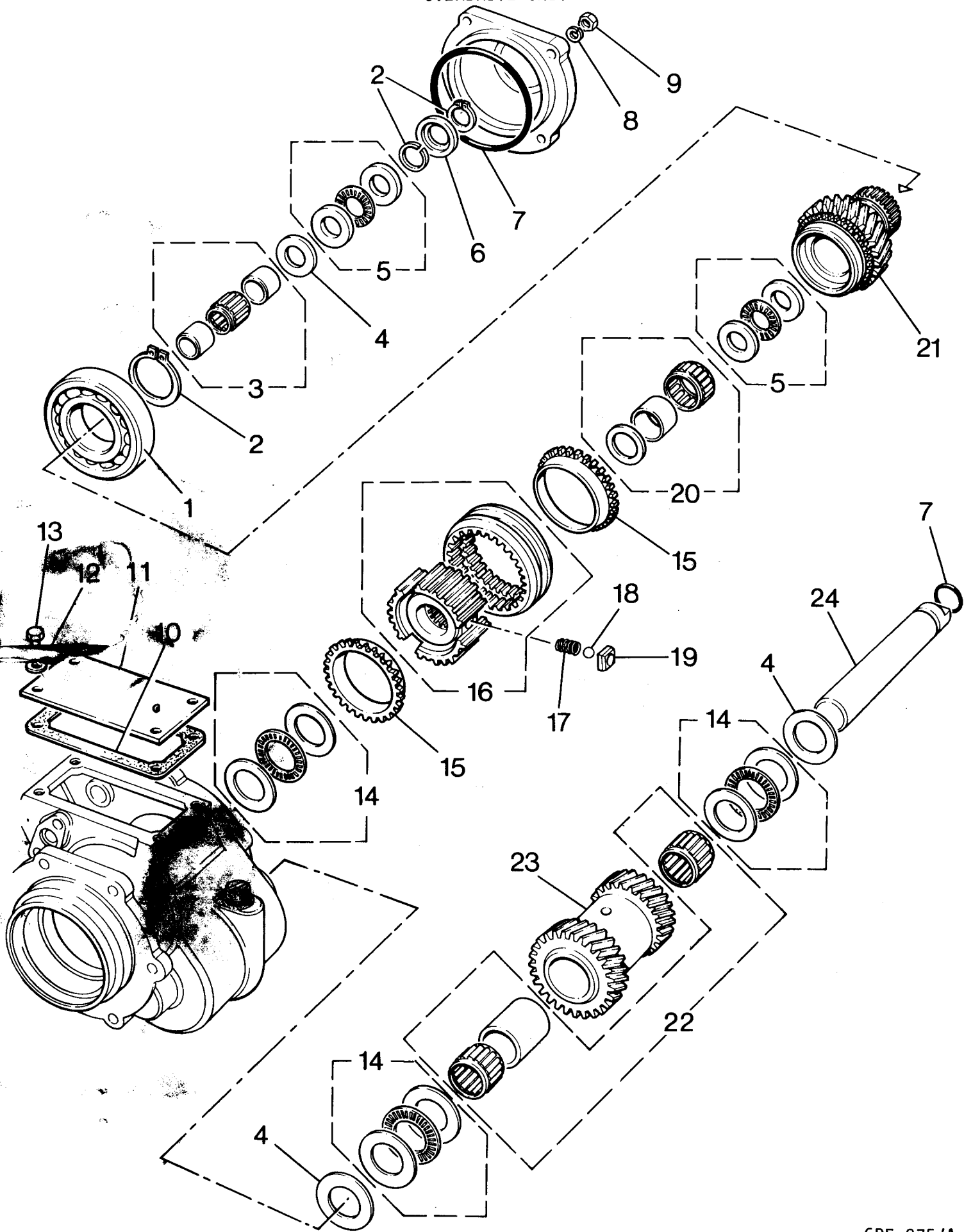

PARTS LIST

Plate Ref	Description	Qty	Part No.
1	Ball bearing	1	1D3790
2	Circlip service kit (comprising 5 items)	1	RTC7172
3	Needle bearing service kit	1	RTC7188
4	Shim pack (comprising 8 assorted shims for laygear and mainshaft)	A/R	RTC7189
5	Thrust bearing service kit	2	RTC7186
6	Collar	1	RTC7190
7	'O' ring service kit	1	RTC7166
8	Spring washer (M8)	4	WM108001
9	Nut	4	GHF213
10	Gasket for top cover plate	1	RTC7182
11	Top cover plate	1	RTC7183
12	Plain washer (M8)	4	WD108051
13	Screw (M8 x 16 mm)	4	SH108161
14	Thrust bearing service kit	3	RTC7184
15	Synchromesh cone	2	571936
16	Inner and outer synchro hub	1	561392
17	Spring	3	503805
18	Ball	3	52459
19	Sliding block	3	553084
20	Needle bearing service kit	1	RTC7185
21	Input gear assembly	1	RTC7187
22	Needle bearing service kit	1	RTC7191
23	Laygear	1	RTC7192
24	Layshaft	1	RTC7194

Note: Parts not carrying a plate reference are NSS (Not supplied separately).

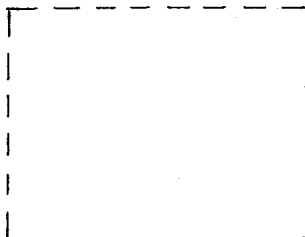

Encloses parts which form an assembly unit.

FITTING INSTRUCTIONS

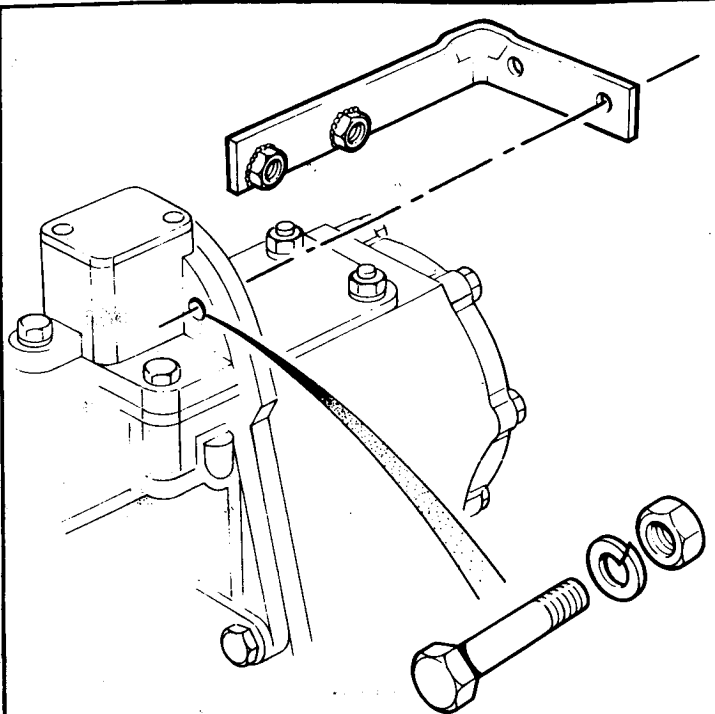

1 Remove centre seat panel. Fit the 'L' shaped bracket to the vertical bolting of the transfer box using the replacement fixings.

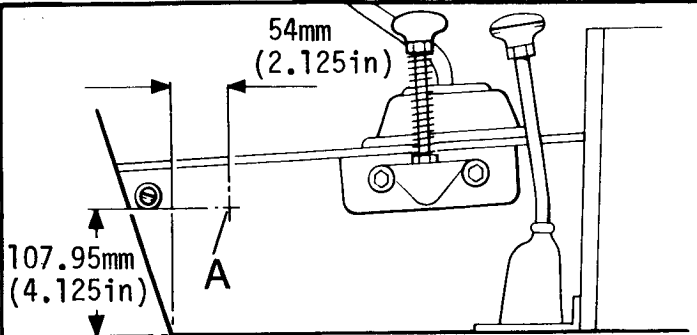

4 CYLINDER

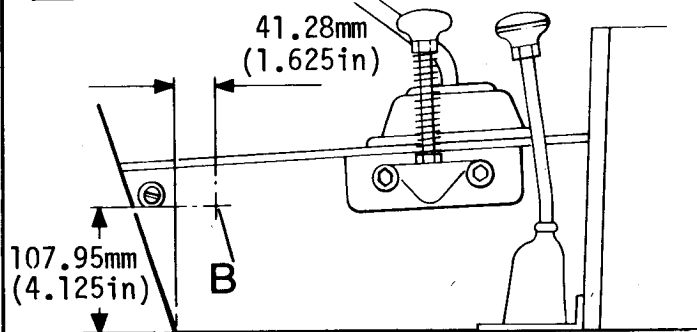

6 CYLINDER

2 Mark and centre punch the transmission tunnel at point A or B whichever is appropriate.

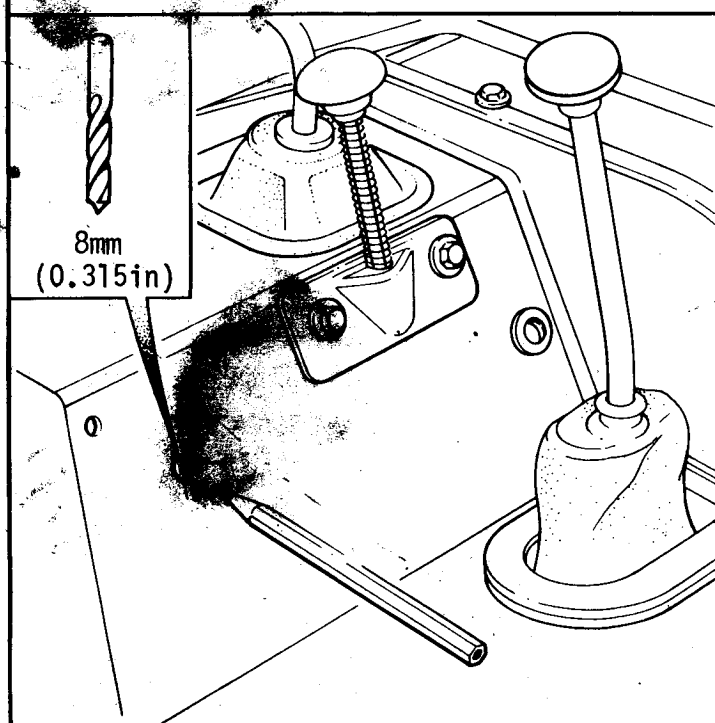

3 Drill a hole at point A or B and with a pencil through the hole, mark the bracket previously fitted.

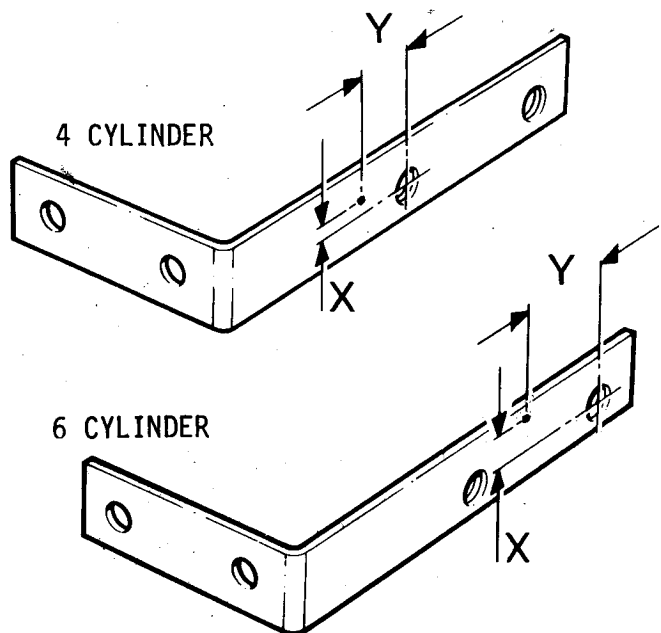

4 CYLINDER

6 CYLINDER

4 Remove the bracket, and from the pencil mark measure distances X and Y in relation to the fixing hole which is going to be used i.e., rear hole for four cylinder models and the front hole for six cylinder vehicles.

FITTING INSTRUCTIONS

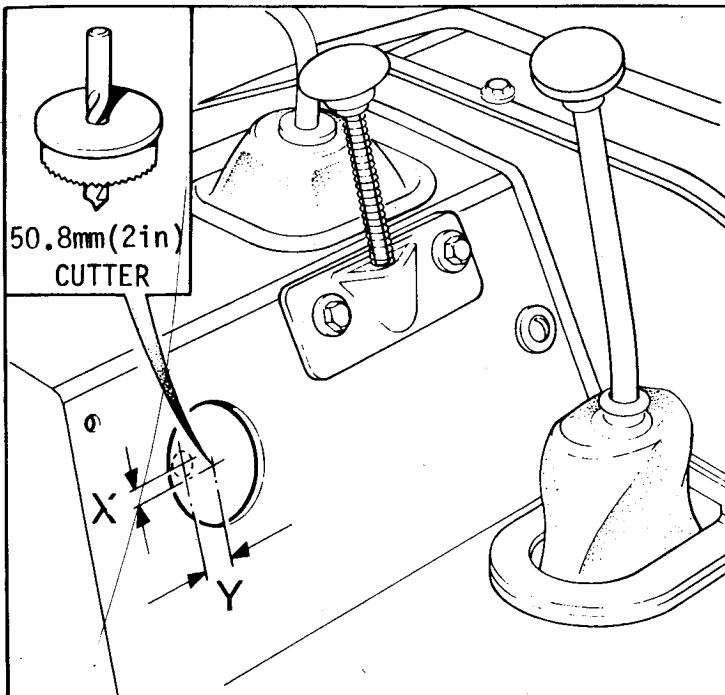

5 Transfer the measurements X and Y onto the transmission tunnel and where the two lines intersect, centre punch and cut a hole to the dimensions shown.

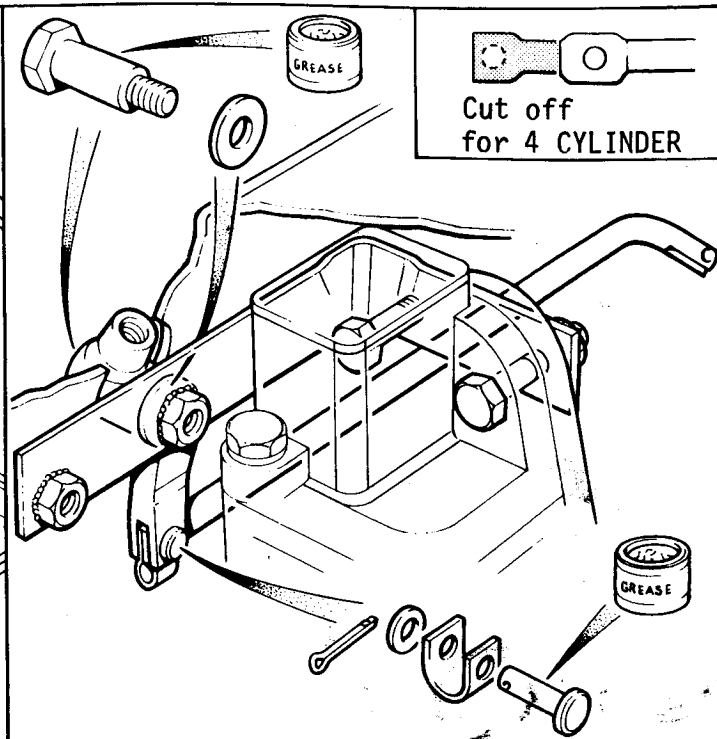

6 Assemble the link rod to the operating pivot and place in position. Refit the shaped bracket to the transfer box and secure the operating pivot to the bracket.

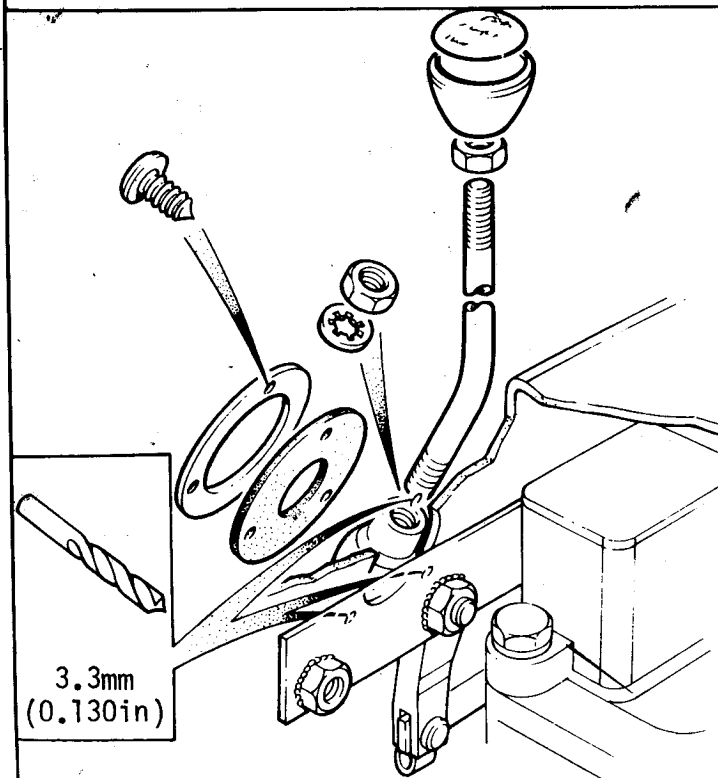

7 Position the rubber grommet and sealing plate over the operating pivot, drill three holes and secure with self tapping screws. Assemble the operating lever and knob and fit to pivot.

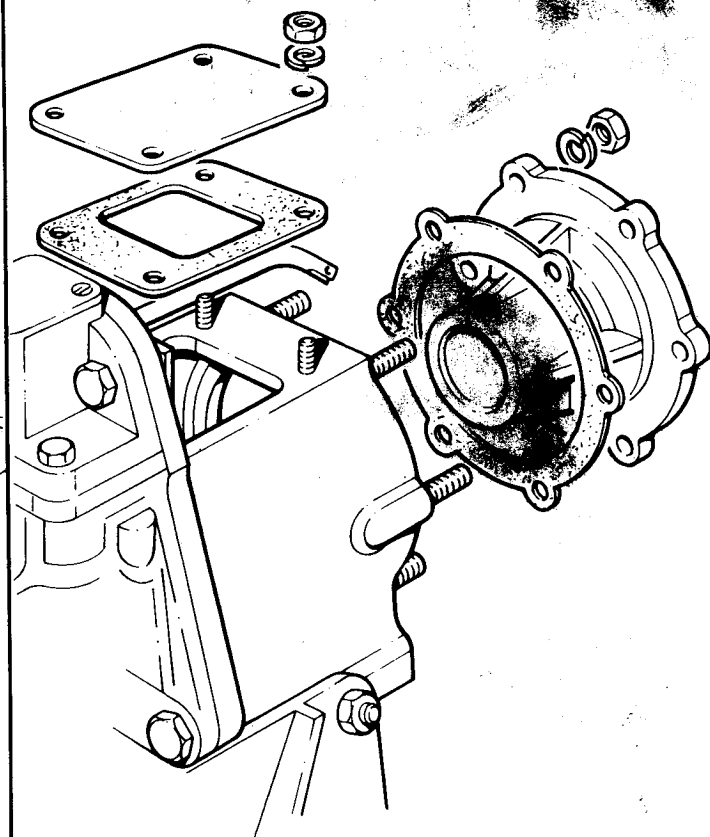

8 Remove rear bearing housing and top cover plate from transfer box.

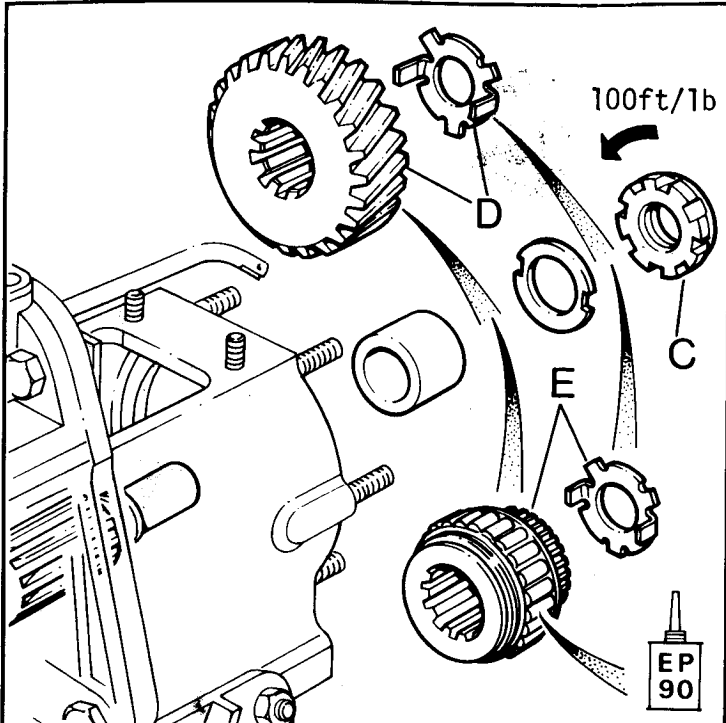

9 Using special spanner 600300, remove mainshaft nut C. Withdraw lockwasher and gear D. Fit clutch sleeve and NEW lockwasher E, ensure that the distance piece and shim (if fitted) are re-assembled in the order shown. Tighten mainshaft nut and lock with washer.

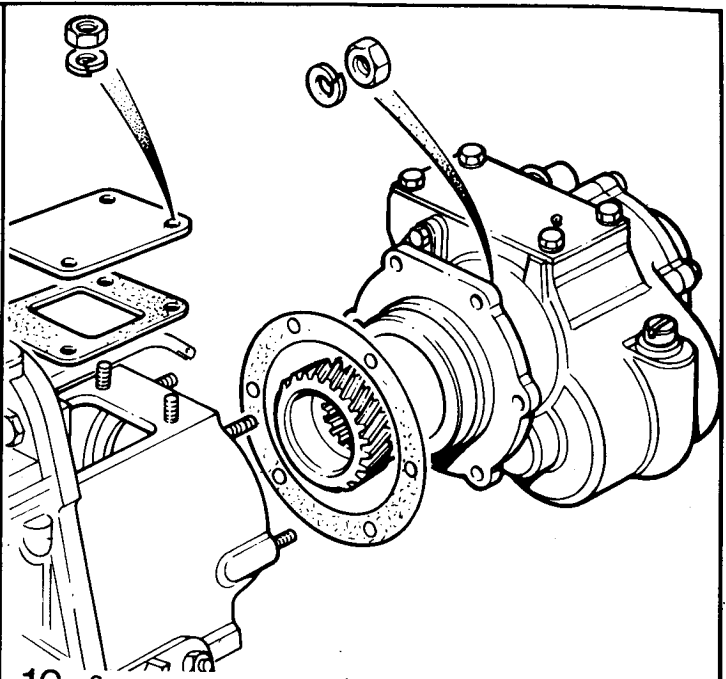

10 Smear grease on both sides of gasket and fit to transfer box studs. On no account must the anti-scuff paste be wiped from the inside of the overdrive mainshaft. Offer overdrive into transfer gearbox (see special notes 11). Ensure the studs do not foul the overdrive casing and secure with original fixings. Refit cover and gasket to top of transfer box.

**11 SPECIAL NOTES**

If difficulty is experienced in engaging the overdrive unit with the vehicle gearbox, the following procedures should be adopted.

**A** If the unit protrudes by 25.4mm (1in). Fit the slotted end of the link rod over the selector shaft of the unit and engage the clevis pin.

Taking suitable safety precautions, release the hand brake and rock the vehicle backwards and forwards by turning the transmission drum, simultaneously pulling the overdrive lever back to slide the unit forward.

**B** If the unit protrudes by 9.5mm (0.375in) Fit the link rod as detailed in A. Engage first gear. Shift the high-low lever (red knob) to neutral.

Simultaneously pull the overdrive lever back and spin the engine a few times using the starter motor until the unit slides completely forward.

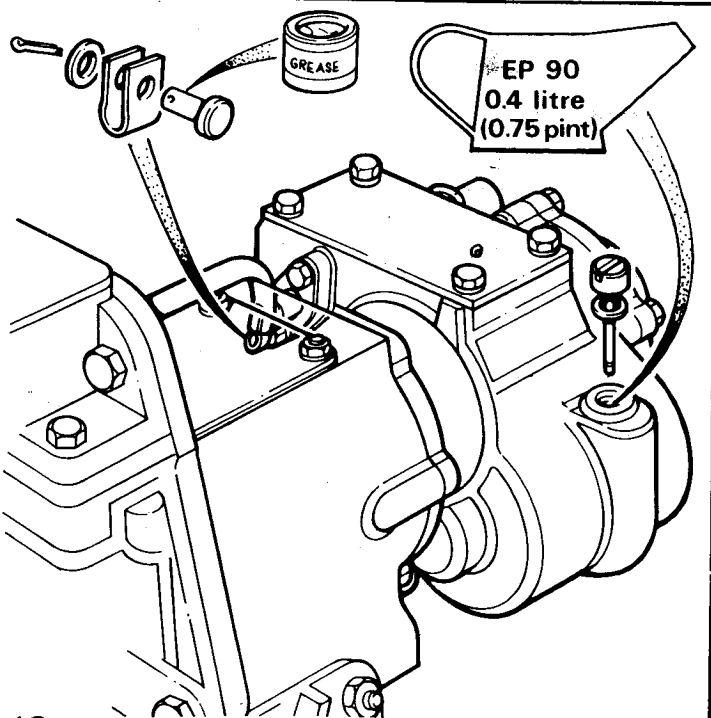

12 Connect link rod to selector shaft. Fill unit with oil. Dipstick reading should be obtained by screwing fully into place. Refit centre seat panel, affix clutch warning label. Adjust the operating lever to a suitable position and road test operation of unit.



TECHNICAL DATA

Overdrive ratio .782:1

See tables for comparisons - figures in brackets are without overdrive.

<u>TOP GEAR - HIGH RATIO</u>				
	88" FITTED WITH 600 x 16 TYRES		38" and 109" FITTED WITH 750 x 16 TYRES	
MPH/1000 RPM	19.17	(15)	21.1	(16.5)
KPH/1000 RPM	30.8	(24.1)	34	(26.6)

<u>TOP GEAR - LOW RATIO</u>				
	88" FITTED WITH 600 x 16 TYRES		38" and 109" FITTED WITH 750 x 16 TYRES	
MPH/1000 RPM	9.2	(7.2)	10.2	(8)
KPH/1000 RPM	14.8	(11.6)	16.5	(12.9)

OPERATING INSTRUCTIONS

The overdrive unit is fitted with a sychromesh gearchange unit and should be treated as an extra gearbox. Since the overdrive gearchange is mechanical, the clutch must be used when changing into or out of overdrive just the same as when changing gear in the gearbox. There are three lever positions, overdrive in, neutral, and overdrive out.

To engage

Simultaneously press the clutch and release the accelerator pedal. Move the overdrive operating lever forward. Simultaneously release the clutch and press the accelerator.

To disengage

Simultaneously press the clutch and release the accelerator pedal. Move the overdrive operating lever backward. Simultaneously release the clutch and press the accelerator.

Running in

To allow the overdrive unit to bed in correctly, it is most important that for the first 500 miles, the Land Rover should be driven conservatively.

MAINTENANCE INSTRUCTIONS

After the first 500 miles drain and refill the overdrive unit with EP90 oil, and repeat this procedure every 6000 miles.

As the overdrive unit's lubrication is independant of the main and transfer gearboxes, it is extremely important that the oil level be checked and maintained on a weekly basis.

Periodically lubricate the selector linkage.