



Land Rover
Optional Equipment
Parts Catalogue

Part No. RTC 9009

June 1973



LAND-ROVER SERIES IIA AND III
OPTIONAL EQUIPMENT PARTS CATALOGUE
BONNETED CONTROL MODELS

First Issue - June 1973

Rover British Leyland
UK Limited



Service Department
Solihull, Warwickshire
Telephone: 021 743 4242
Telegrams: Rovrepair Solihull
Telex: 338641

Parts Department
P O Box 79
Cardiff
Great Britain
Telephone: Cardiff 33681
Telegrams: Rovparts, Cardiff
Telex: 49-359

Please note that all prices and specifications
are subject to alteration without notice

Always quote type and number of vehicle
when ordering

By Appointment to
Her Majesty
Queen Elizabeth II



Manufacturers
of Motor Cars and
Land-Rovers

By Appointment to
Her Majesty
Queen Elizabeth
the Queen Mother



Suppliers
of
Motor Cars and
Land-Rovers

GROSS INDEX. INDEKS. GRUPPER. INHOUD-HOOFDSTUKKEN. RYHMAHAKEMISTO. TABLE DES SECTIONS.
GRUPPENVERZEICHNIS. INDICE DEI GRUPPI. NUMBERACAO DE GRUPO. INDICE DEL GRUPO. GRUPINDEX.

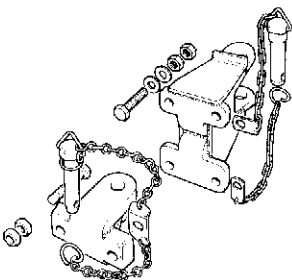
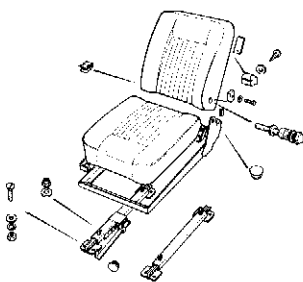
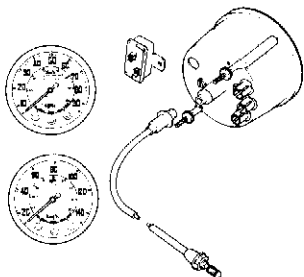
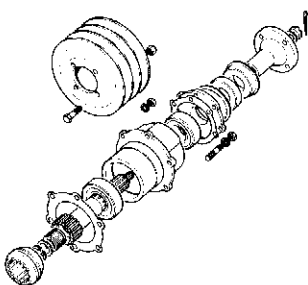
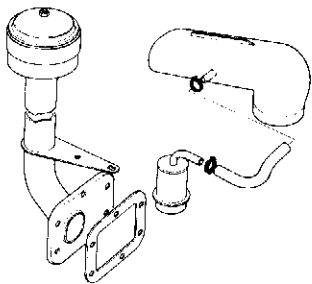

25 01
to
26 65

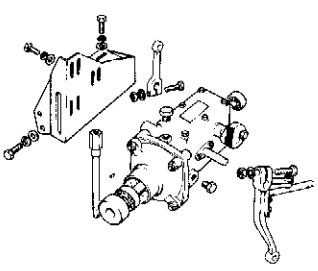
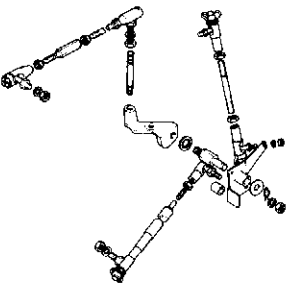
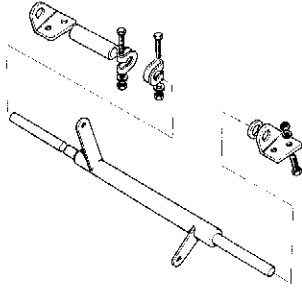
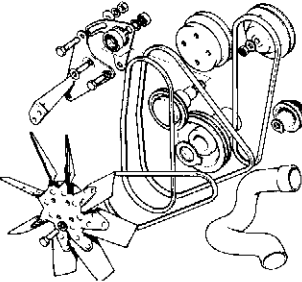
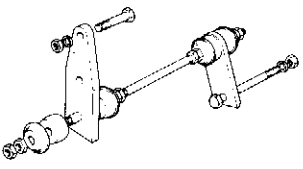
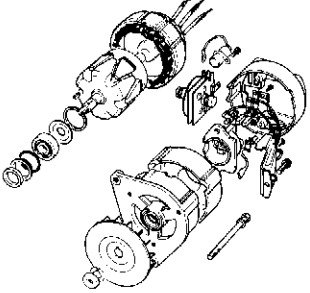
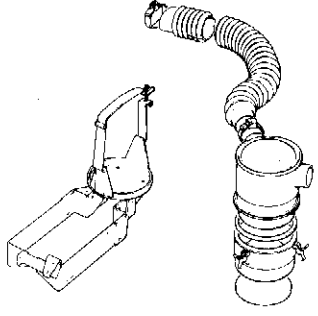
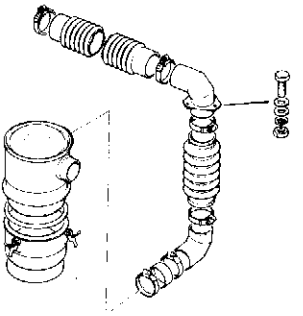
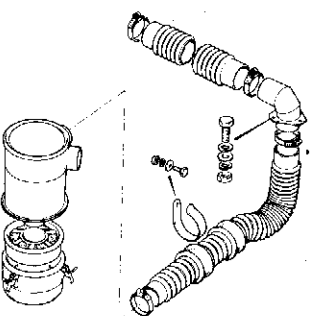
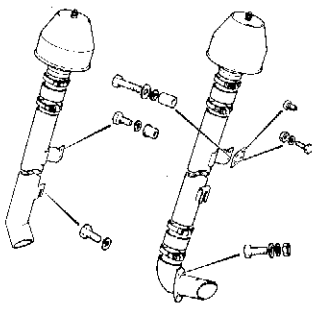
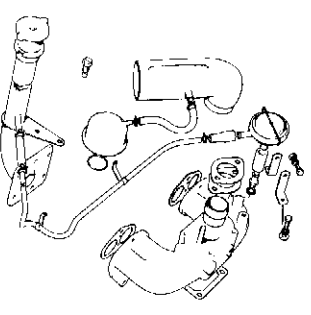
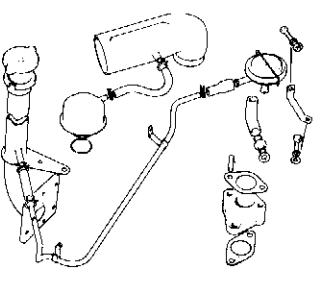
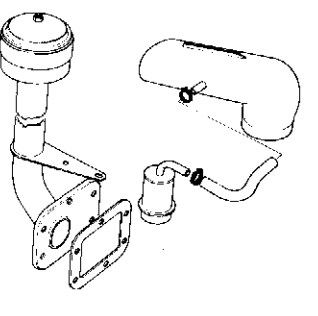
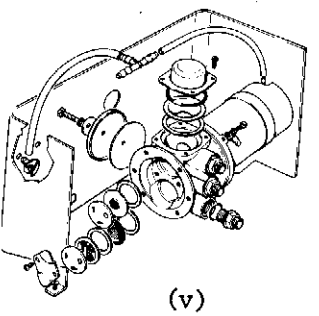
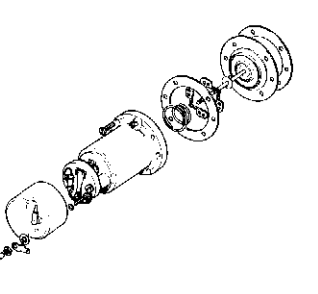
 <p>25 01</p>	 <p>25 02</p>	 <p>25 03</p>
 <p>25 04</p>	 <p>25 05</p>	 <p>25 06</p>
 <p>Series IIA 2 1/4 Petrol 25 10</p>	 <p>Series III 2 1/4 Models 25 11</p>	 <p>Series III 2.6 Models 25 12</p>
 <p>25 13</p>	 <p>Series IIA 25 14</p>	 <p>Series III 25 15</p>
 <p>25 16</p>	 <p>25 17 (v)</p>	 <p>25 18</p>

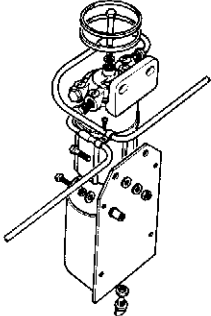
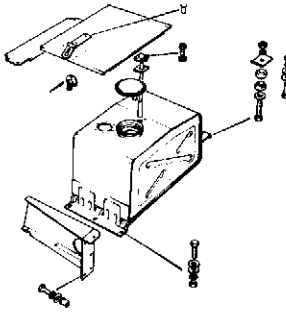
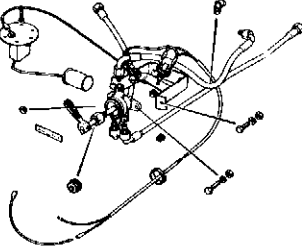
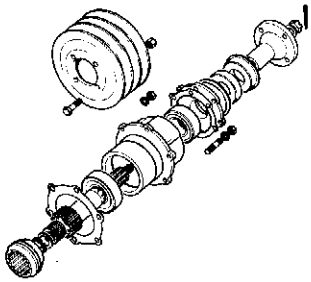
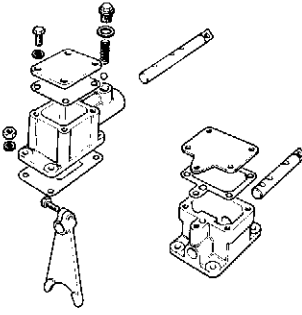
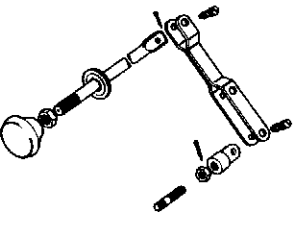
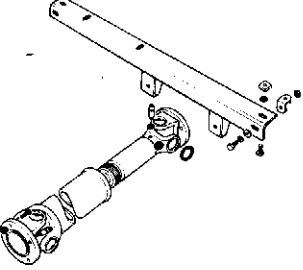
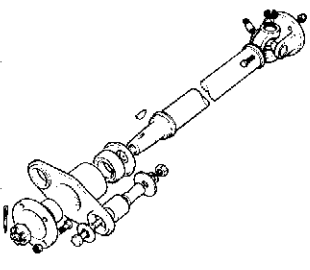
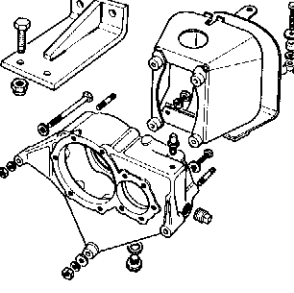
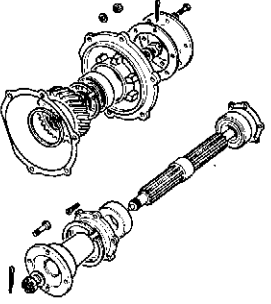
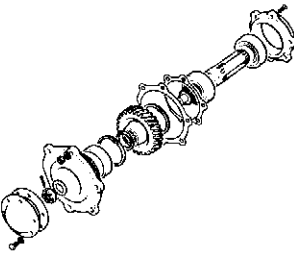
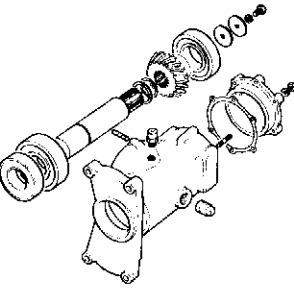
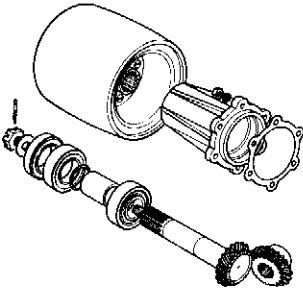
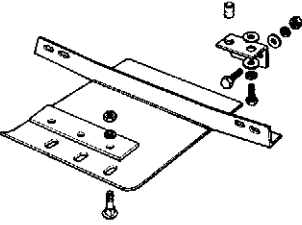
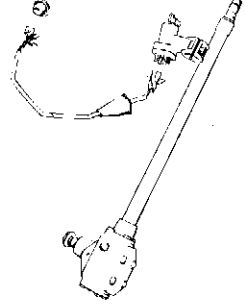
		
		
		
		
	 <p>(vi)</p>	

25 19

25 22

25 23

25 25

25 26

25 27

25 28

25 29

25 30

25 31

25 32

25 33

25 34

25 35

25 38

PAGE INDEX. INDEKS SIDER. INHOUD-BLADZIJDEN. SIVUHAKEMISTO. INDEX. SEITENVERZEICHNIS.
 INDICE DELLE PAGINE. NUMERAÇÃO DE PAGINA. INDICE DE LA PAGINA SIDOINDEX

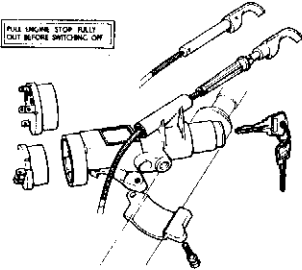
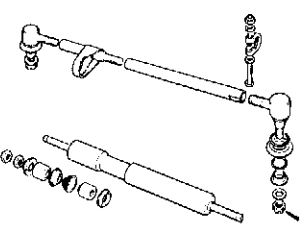
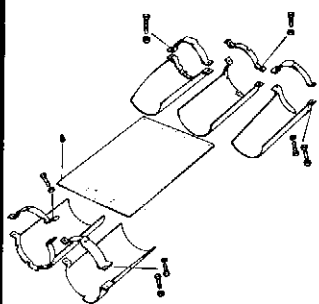
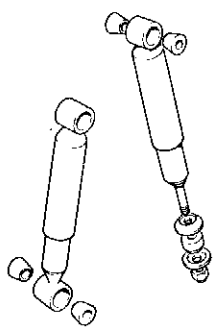
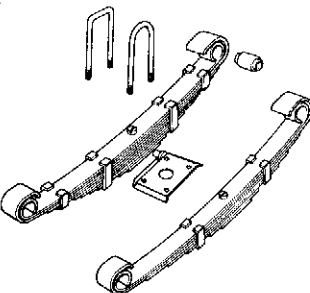
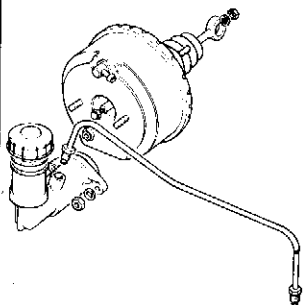
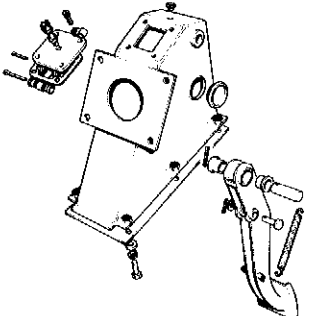
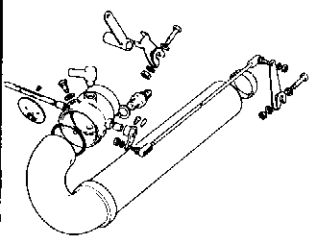
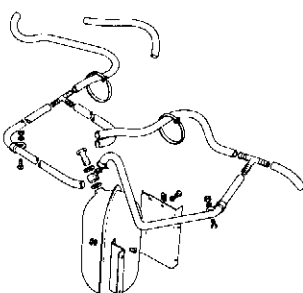
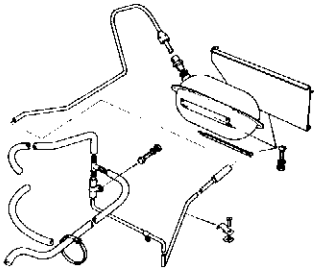
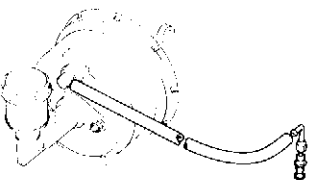
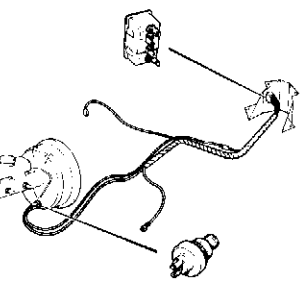
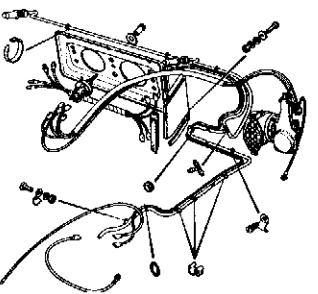
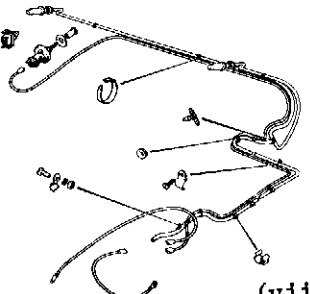
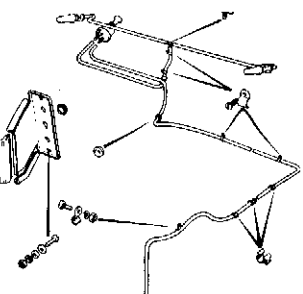
 <p>25 39</p>	 <p>25 40</p>	 <p>25 42</p>
 <p>25 44</p>	 <p>25 45</p>	 <p>25 48</p>
 <p>25 49</p>	 <p>25 50</p>	 <p>25 51</p>
 <p>25 52</p>	 <p>25 53</p>	 <p>25 54</p>
 <p>25 57</p>	 <p>25 58 (vii)</p>	 <p>25 59</p>

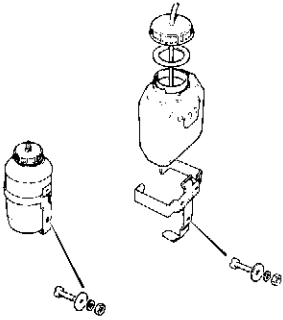
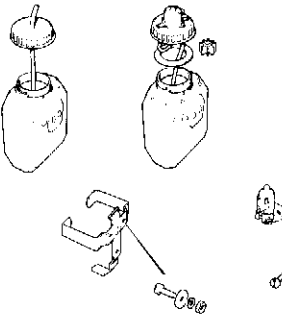
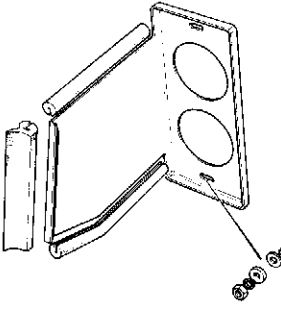
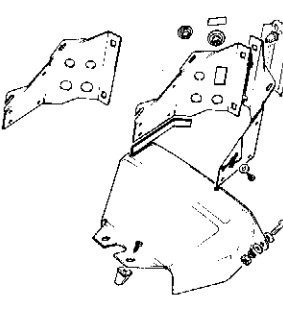
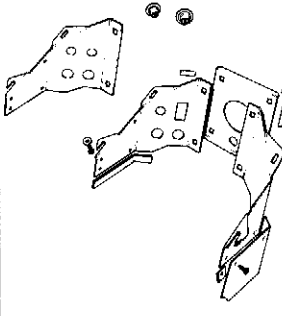
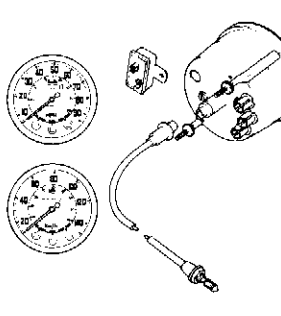
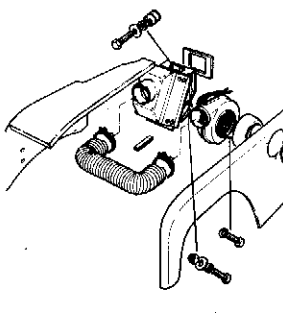
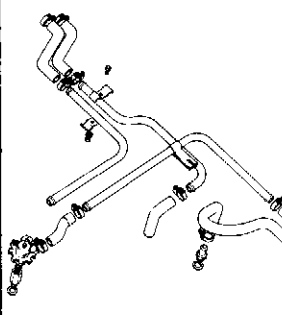
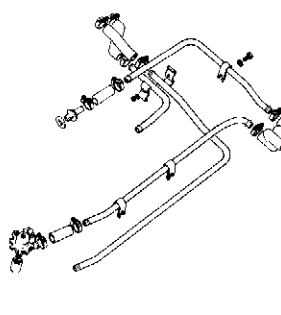
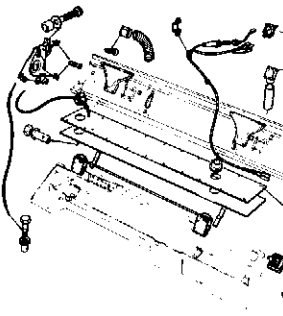
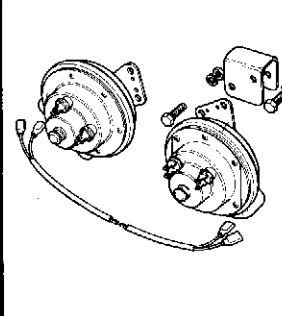
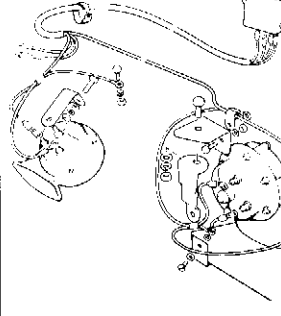
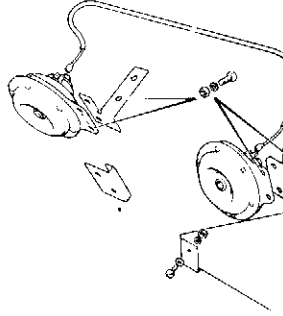
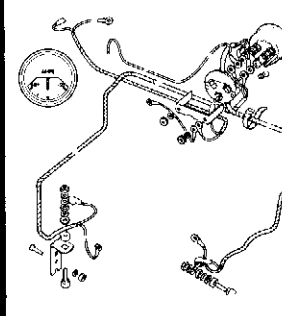
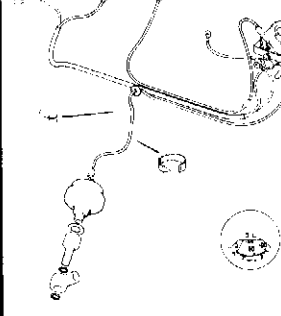
 <p>25 60</p>	 <p>25 61</p>	 <p>25 65</p>
 <p>25 66</p>	 <p>25 67</p>	 <p>25 69</p>
 <p>25 70</p>	 <p>2½ Models 25 71</p>	 <p>2.6 Models 25 72</p>
 <p>25 73</p>	 <p>25 77</p>	 <p>25 78</p>
 <p>25 79</p>	 <p>25 81 (viii)</p>	 <p>25 82</p>

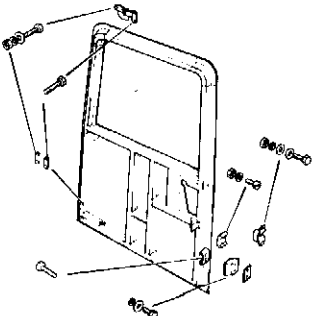
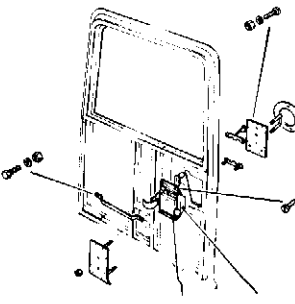
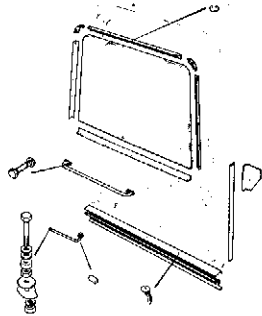
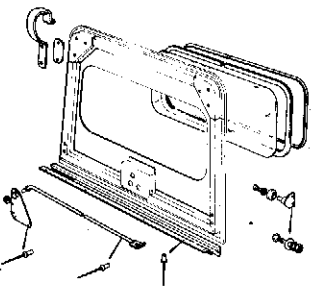
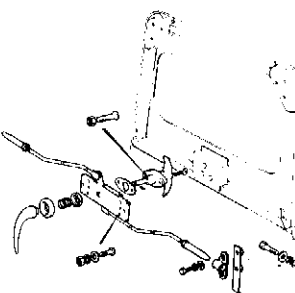
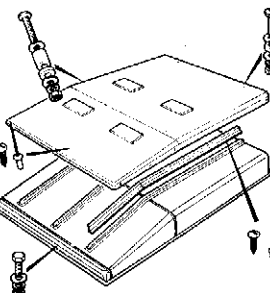
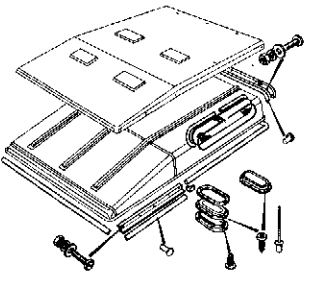
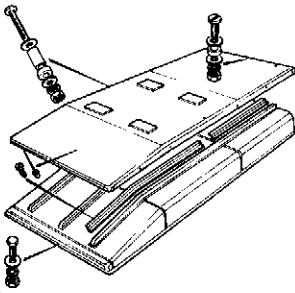
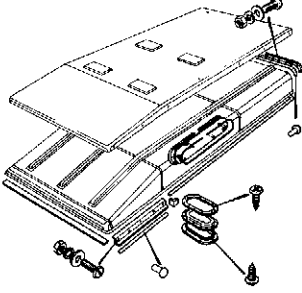
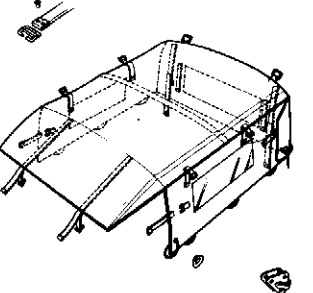
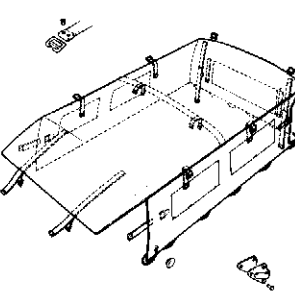
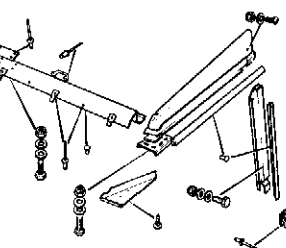
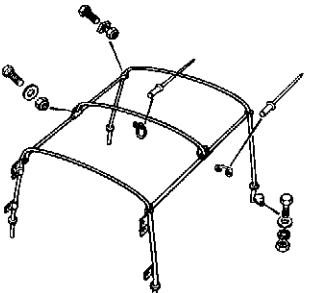
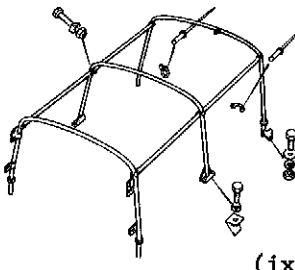
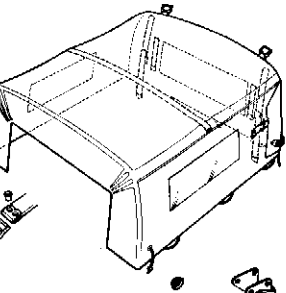
 <p>26 01</p>	 <p>26 02</p>	 <p>26 03</p>
 <p>26 04</p>	 <p>26 05</p>	 <p>88 in. 26 06</p>
 <p>88 in. 26 07</p>	 <p>109 in. 26 08</p>	 <p>109 in. 26 09</p>
 <p>88 in. 26 10</p>	 <p>109 in. 26 11</p>	 <p>26 12</p>
 <p>88 in. 26 13</p>	 <p>109 in. 26 14 (ix)</p>	 <p>88 in. 26 15</p>

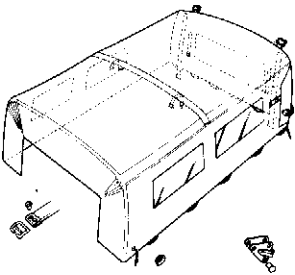
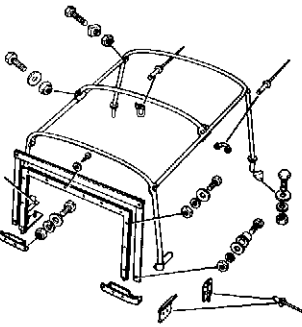
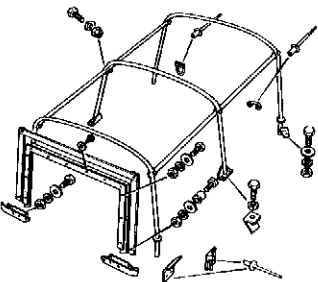
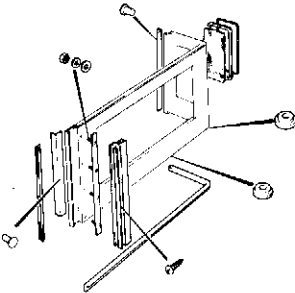
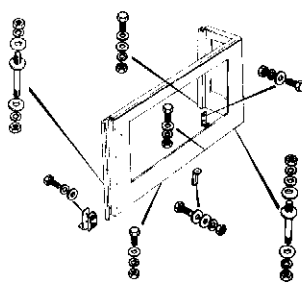
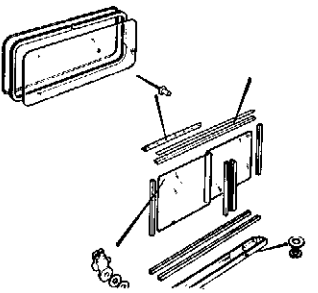
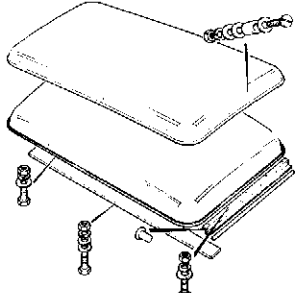
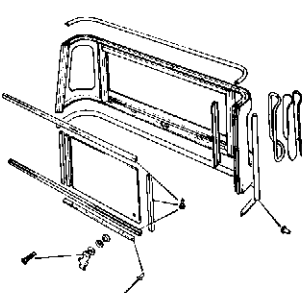
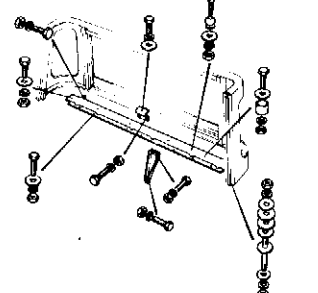
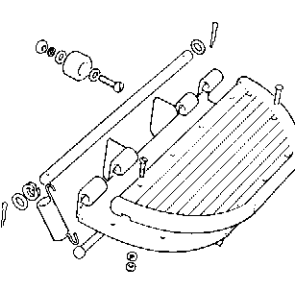
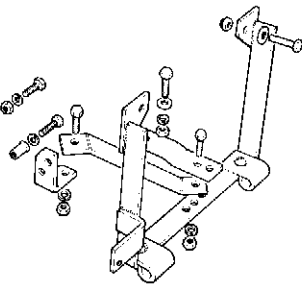
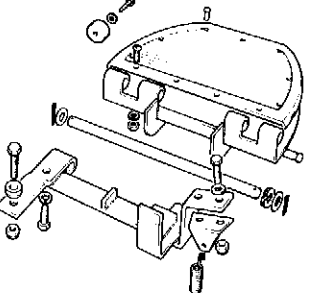
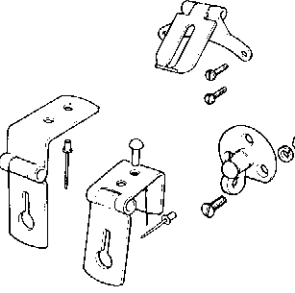
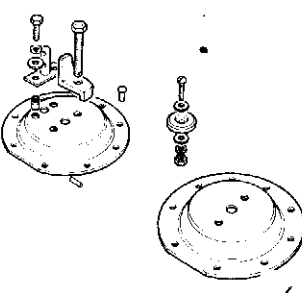
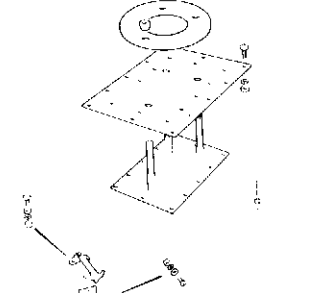
 <p>109 in. 26 16</p>	 <p>88 in. 26 17</p>	 <p>109 in. 26 18</p>
 <p>26 19</p>	 <p>26 20</p>	 <p>26 21</p>
 <p>26 22</p>	 <p>26 23</p>	 <p>26 24</p>
 <p>26 27</p>	 <p>26 28</p>	 <p>26 29</p>
 <p>26 30</p>	 <p>26 31 (x)</p>	 <p>26 32</p>

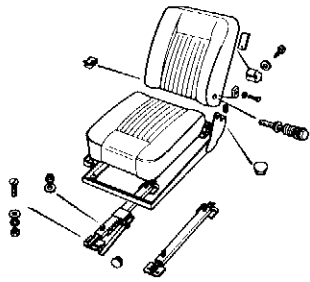
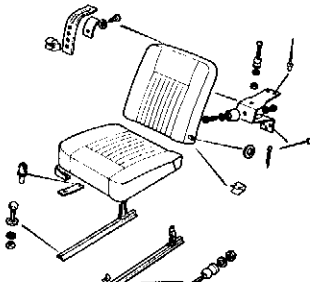
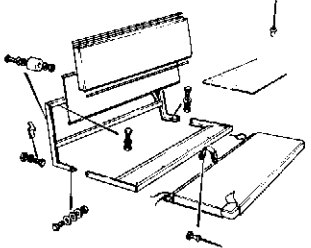
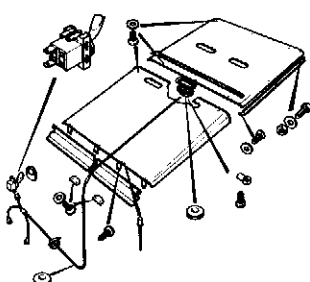
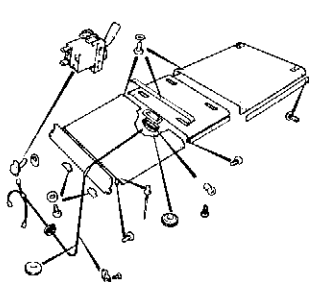
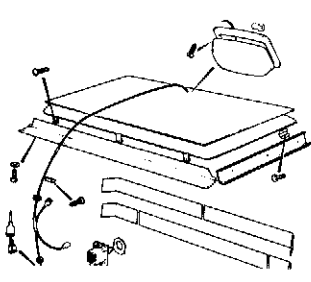
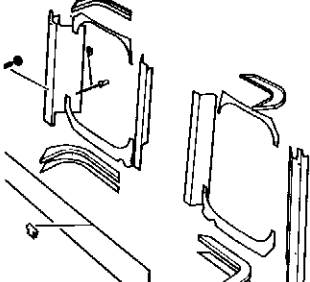
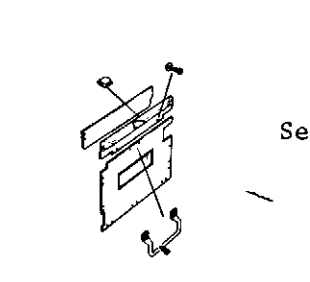
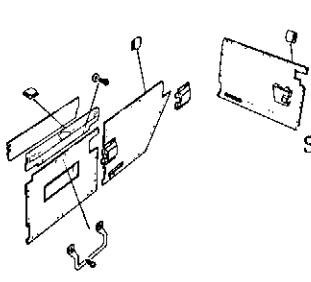
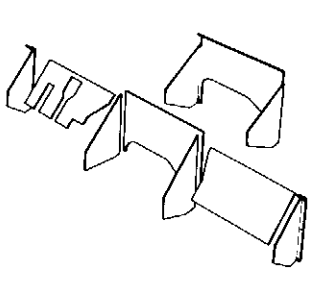
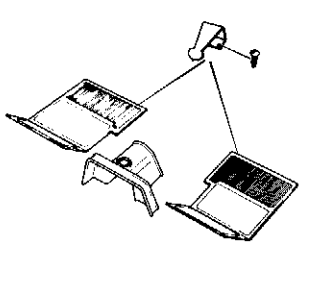
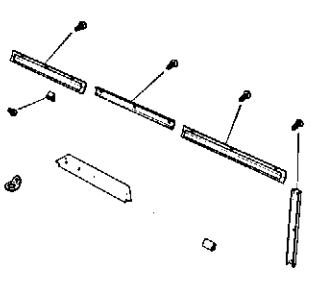
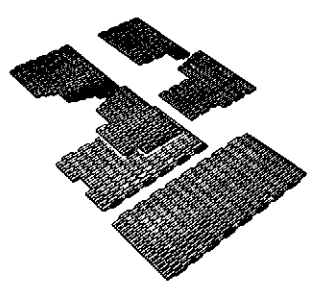
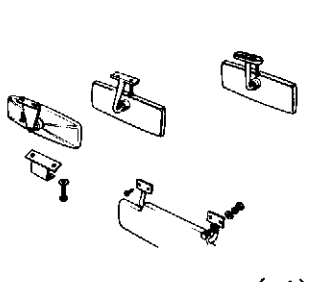
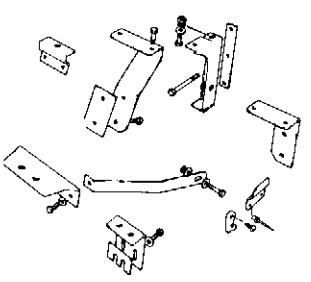
 <p>26 33</p>	 <p>26 34</p>	
 <p>26 37</p>	 <p>26 38</p>	 <p>26 39</p>
 <p>26 40</p>	 <p>Series IIA 26 41</p>	 <p>Series II 26 42</p>
 <p>26 43</p>	 <p>26 44</p>	 <p>26 45</p>
 <p>26 48</p>	 <p>26 49</p> <p>(xi)</p>	 <p>26 51</p>

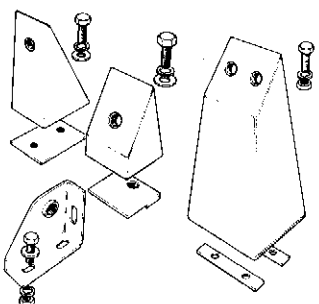
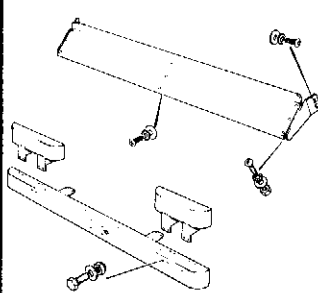
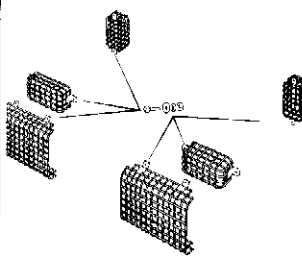
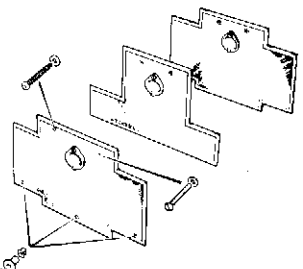
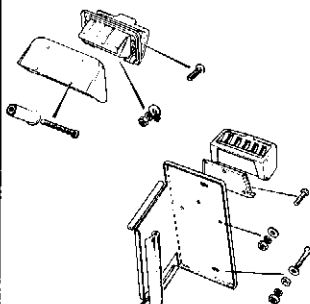
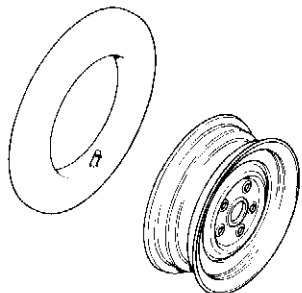
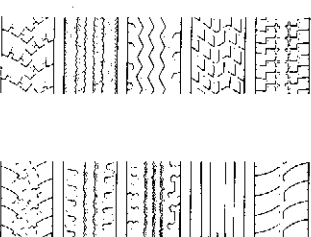
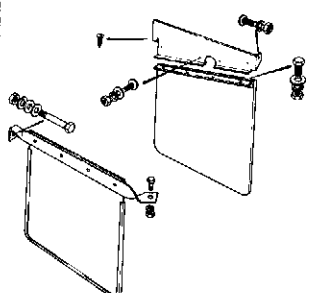
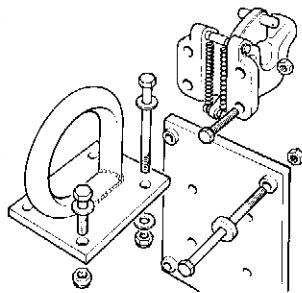
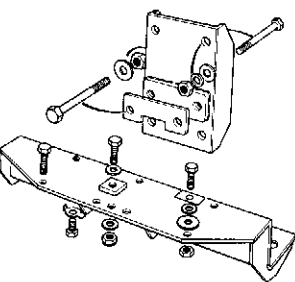
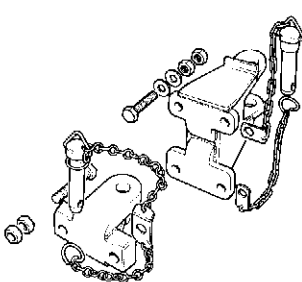
 <p>26 52</p>	 <p>26 54</p>	 <p>26 55</p>
 <p>26 56</p>	 <p>26 57</p>	 <p>26 59 -</p>
 <p>26 60</p>	 <p>26 61</p>	 <p>26 63</p>
 <p>26 64</p>	 <p>26 65</p>	

GOVERNOR, MOUNTING BRACKET AND FIXINGS .SERIES IIA AND III.

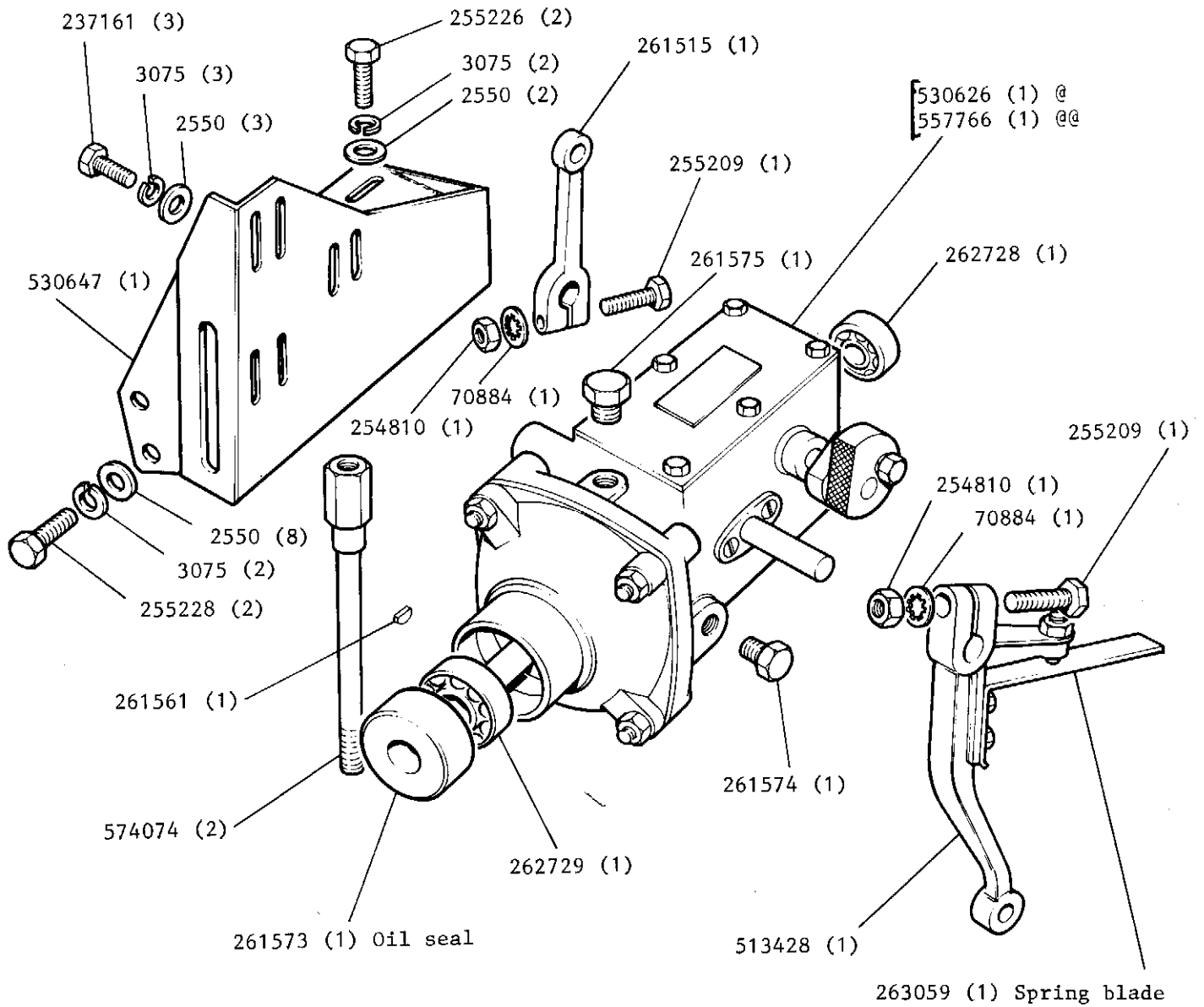

REMARKS

@ Up to engine suffix H inclusive

@@ From engine suffix J onwards and Series III

GOVERNOR CONTROL LEVERS AND FIXINGS, SERIES IIA AND III

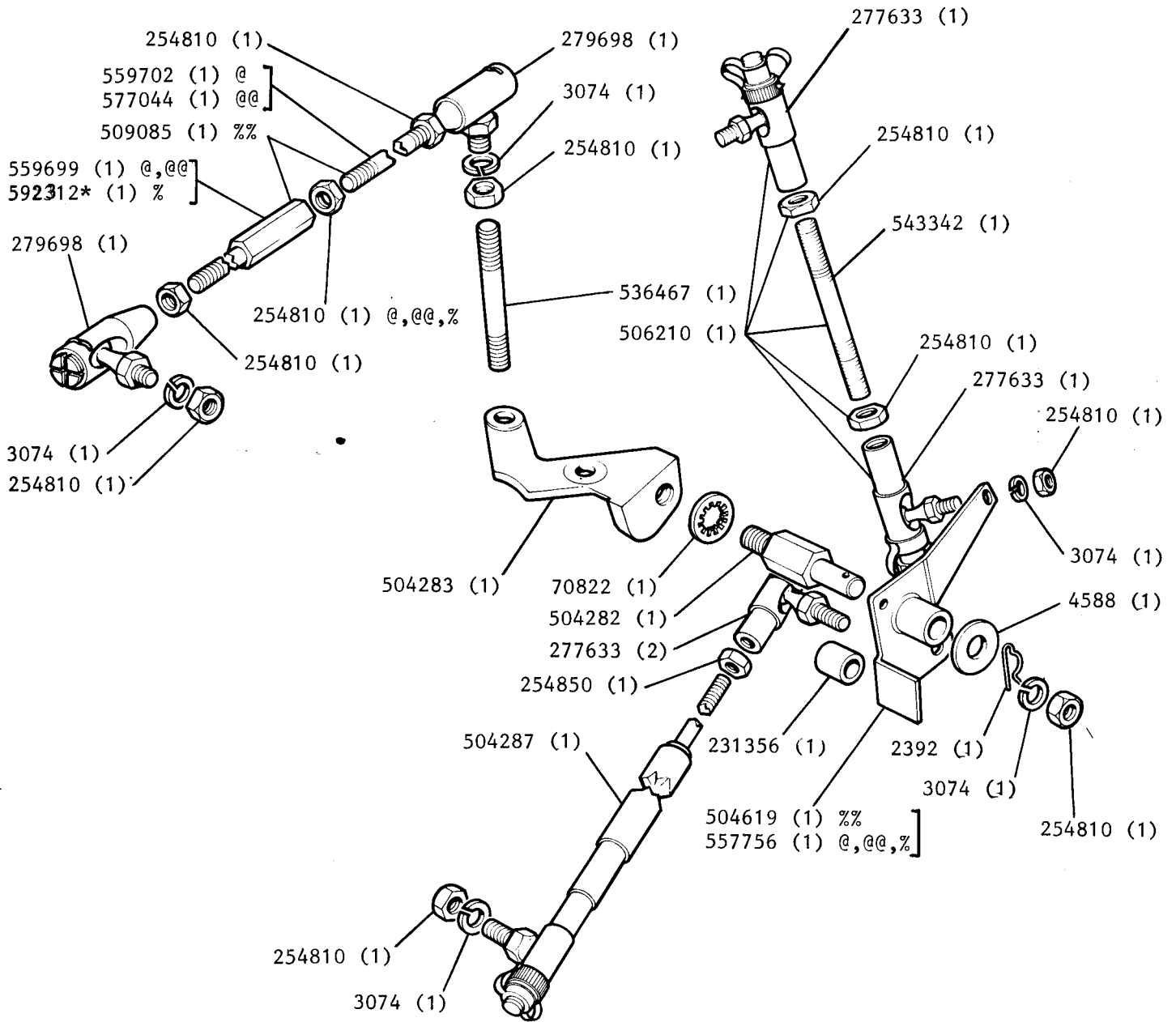

REMARKS

- @ Series IIA from engine suffix J up to 30th September 1968
- @@ Series IIA from 1st October 1968 onwards
- % Series III
- %% Series IIA up to engine suffix H inclusive

RELAY TUBE AND LEVER, BRACKETS AND FIXINGS SERIES IIA AND III

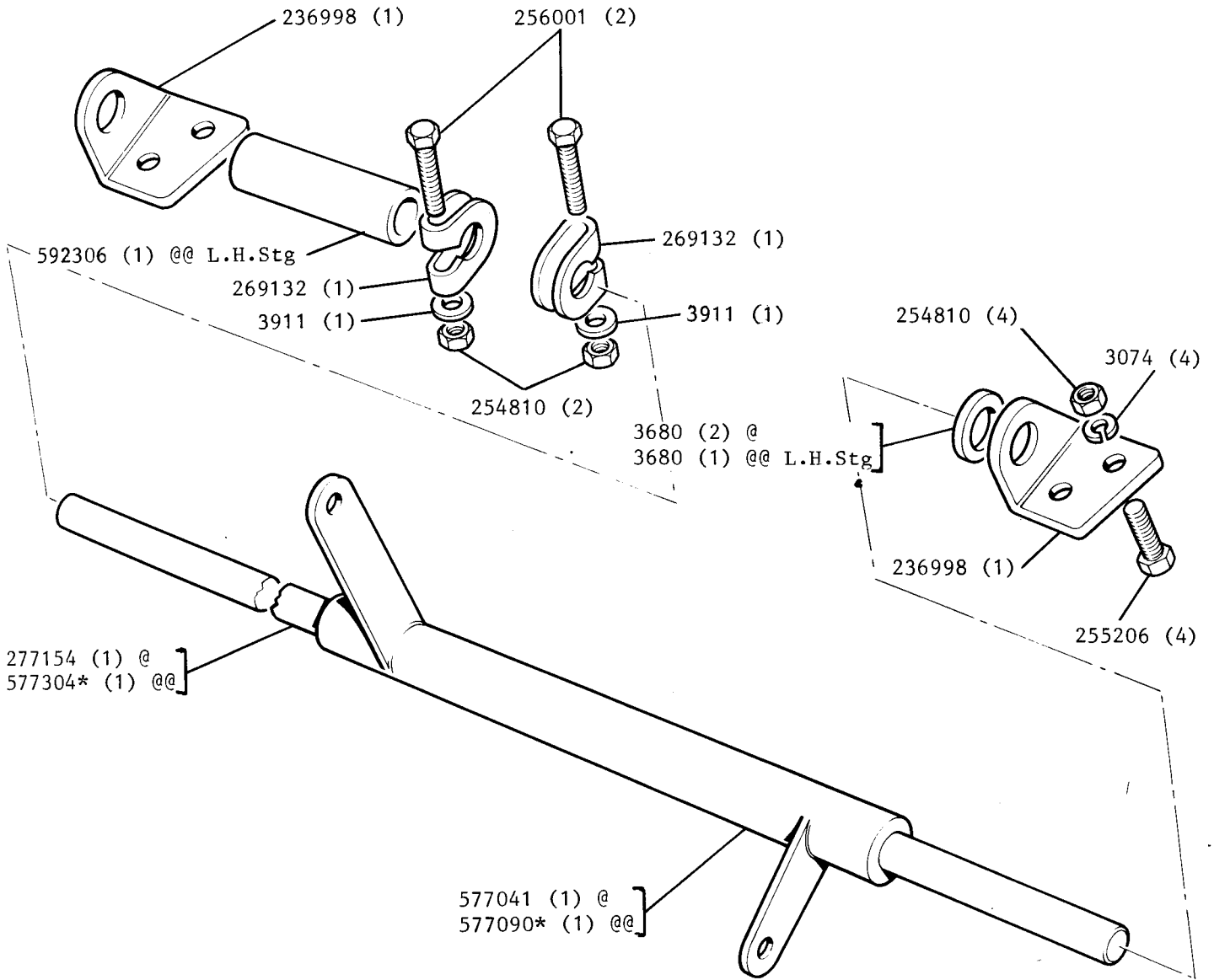

REMARKS

@ Series IIA from 1st October 1968 onwards

@@ Series III

FAN, PULLIES AND DRIVE BELTS FOR ENGINE GOVERNOR SERIES IIA AND III

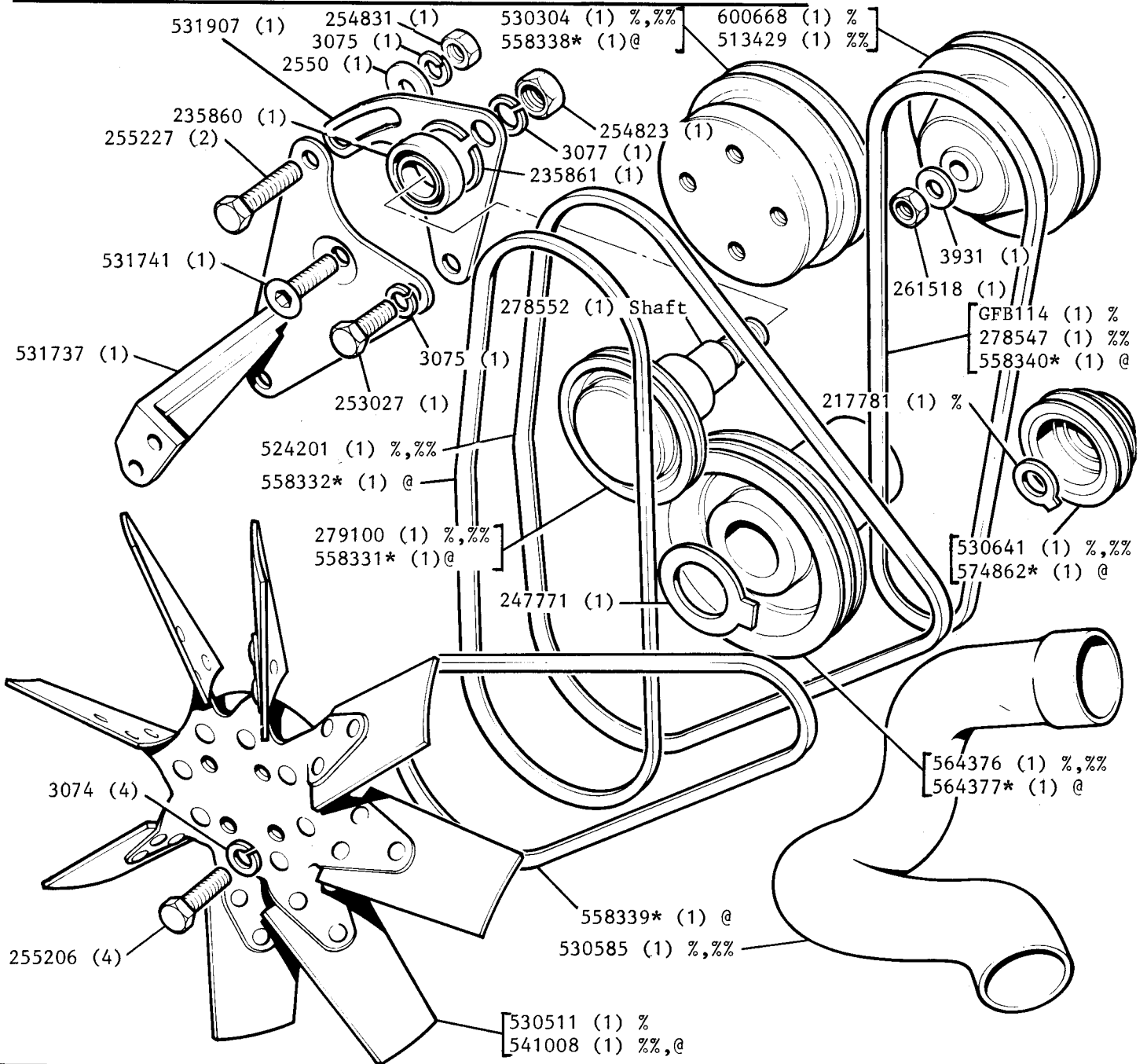

REMARKS

- @ Series III
- % Series IIA up to engine suffix H inclusive
- %% Series IIA from engine suffix J onwards

TIE ROD FOR ENGINE SERIES IIA AND III

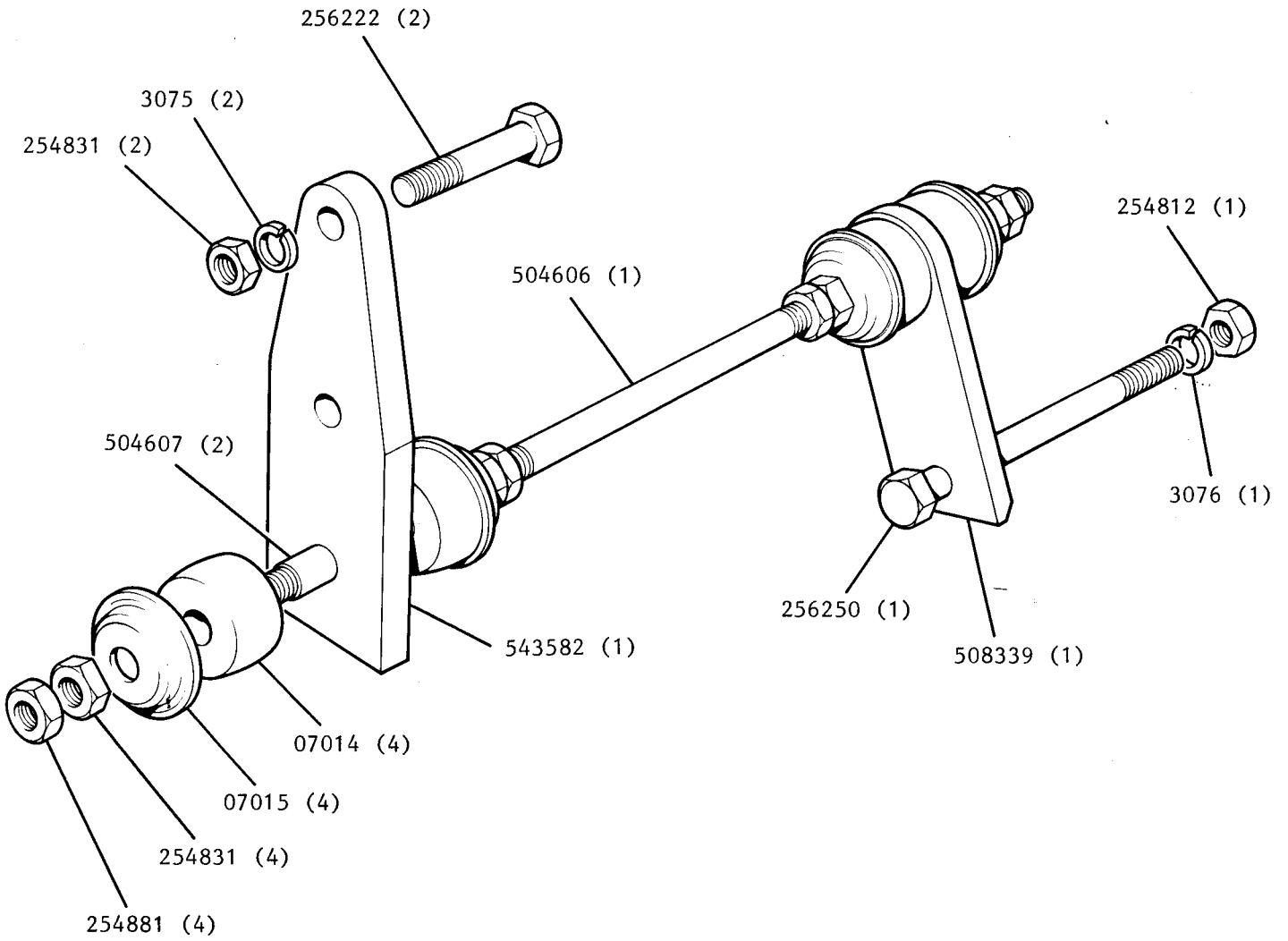

REMARKS

ALTERNATOR 18 ACR BATTERY SENSED SERIES III

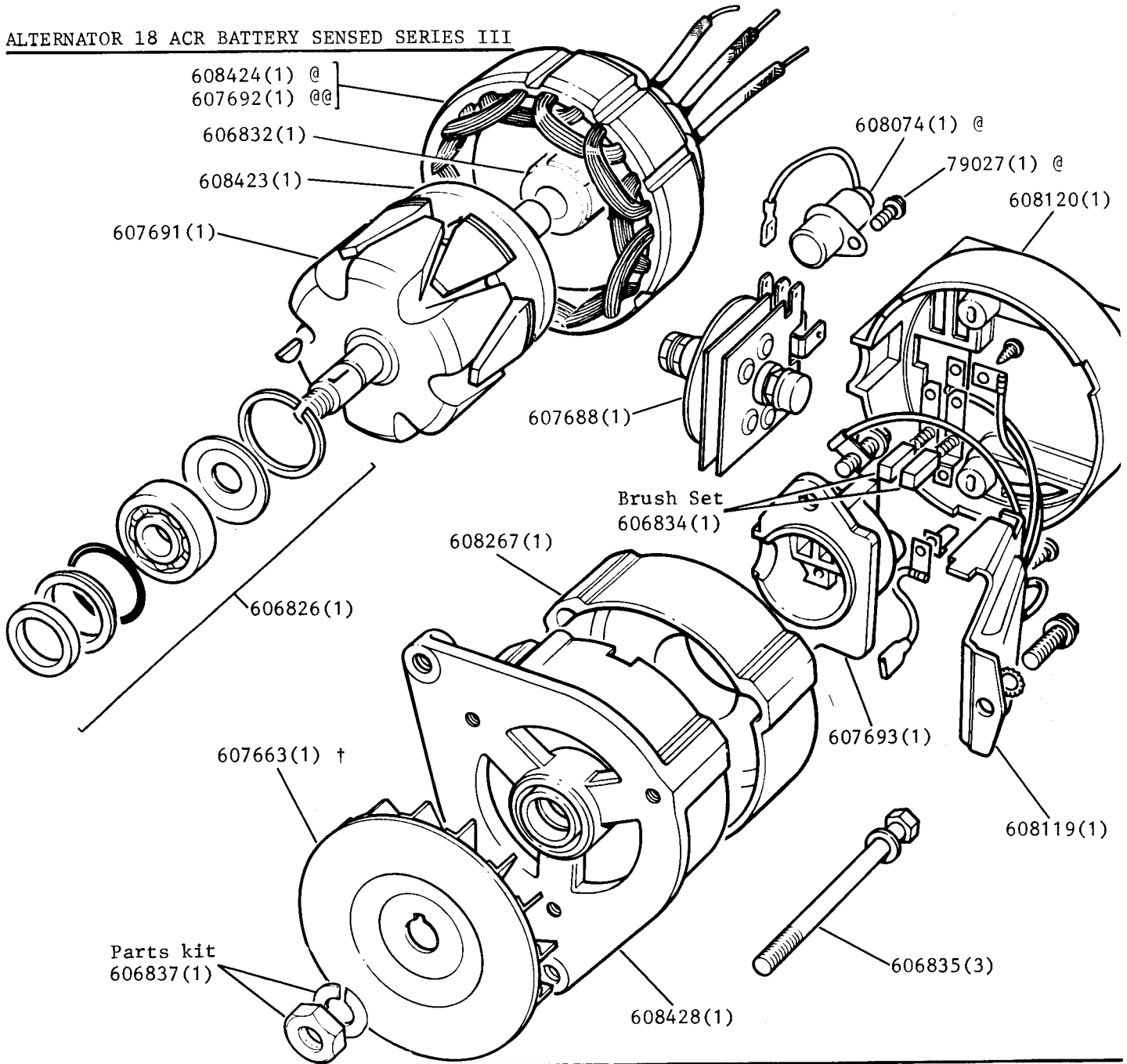

REMARKS

Surge Protection Device 608425(1)

@ Part of Alternator Assembly 608427

@@ Part of Alternator Assemblies 589065 and 608305

† Part of Alternator Assembly 589065, not part of Alternator Assemblies 608305 and 608427

Alternator 18 ACR kit 607608(1) 2½ petrol] Comprises of the following
Alternator 18 ACR kit 607609(1) 2.6 petrol	
Alternator 18 ACR kit 607610(1) 2½ diesel	

Alternator 18 ACR 589065(1) Lucas 23684] Alternatives
Alternator 18 ACR 608305(1) Lucas 23697	
Alternator 18 ACR 608427(1) Lucas 23739	

Cable assembly 589067(1) 2½ petrol] For vehicles with an automatically operated choke warning light	
Cable assembly 589069(1) 2.6 petrol		
Cable assembly 589859(1) 2½ petrol] For vehicles with a manually operated choke warning light
Cable assembly 589860(1) 2.6 petrol		
Cable assembly 589068(1) 2½ diesel		

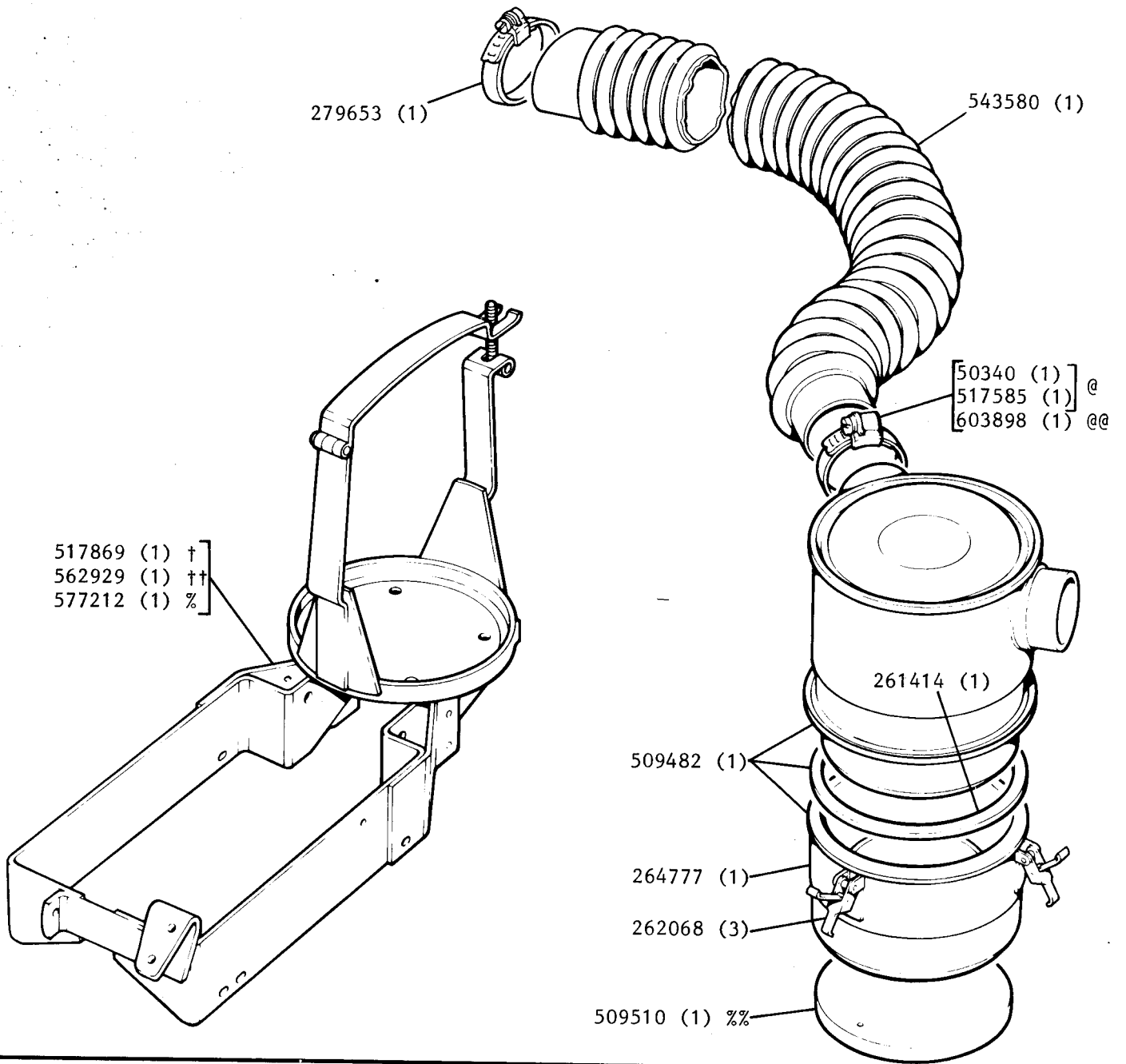

REMARKS

@ Alternatives. Up to December 1968

@@ From January 1969 onwards

† Up to vehicle serial number 26409160C and 24429283C

†† From vehicle serial number 26409161C and 24429284C to July 1969

% From August 1969 onwards

%% Up to July 1969

For raised air intake kit part numbers see frame 25 13

RAISED AIR INTAKE AIR CLEANER, ELBOW AND HOSES.

SERIES III 2 1/4 PETROL AND DIESEL

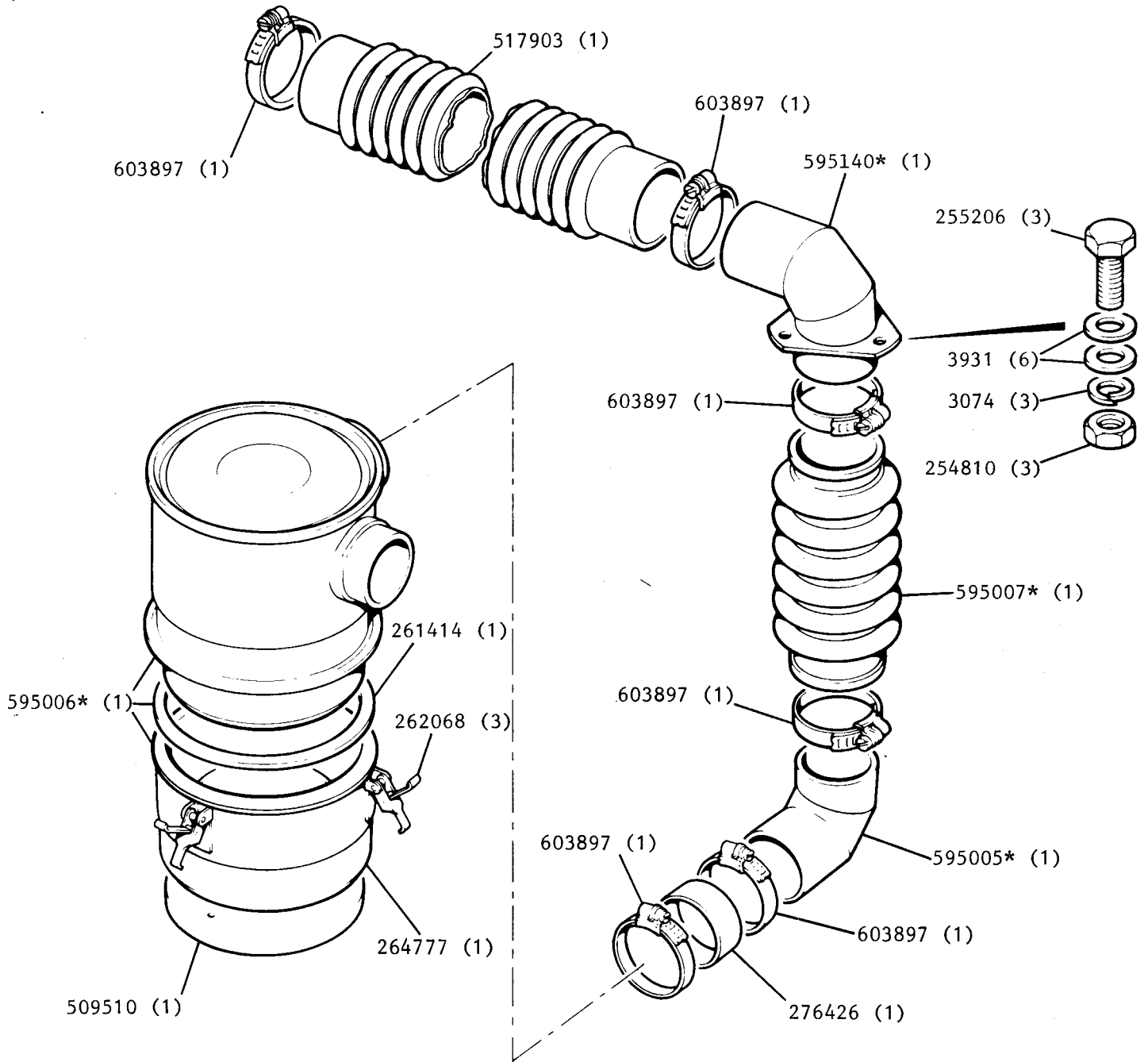

REMARKS

For raised air intake kit part numbers see frame 25 13

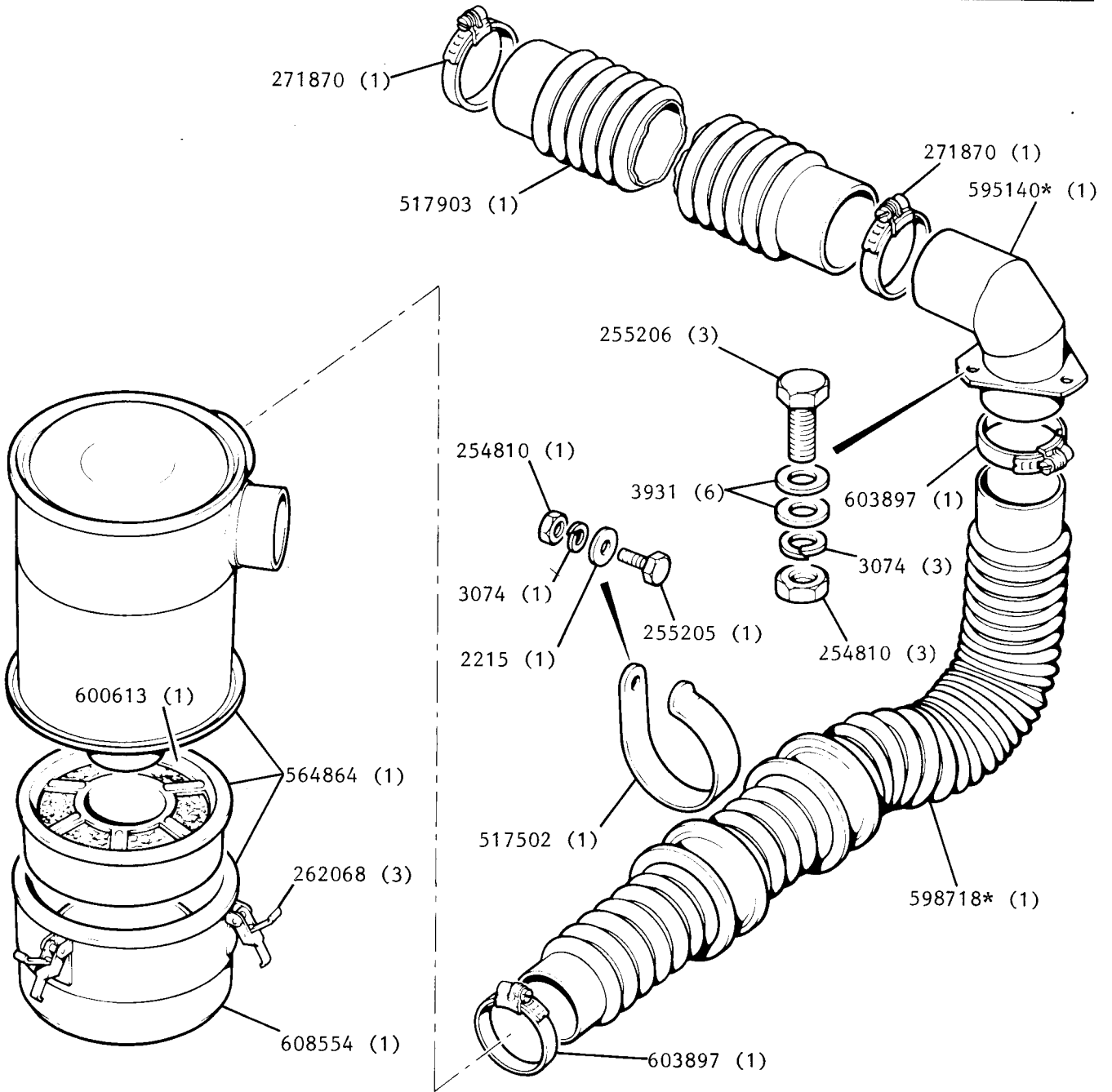

REMARKS

For raised air intake kit part numbers see frame 25 13

RAISED AIR INTAKE PIPE AND CENTRIFUGAL AIR CLEANER

SERIES IIA 2½ PETROL AND SERIES III

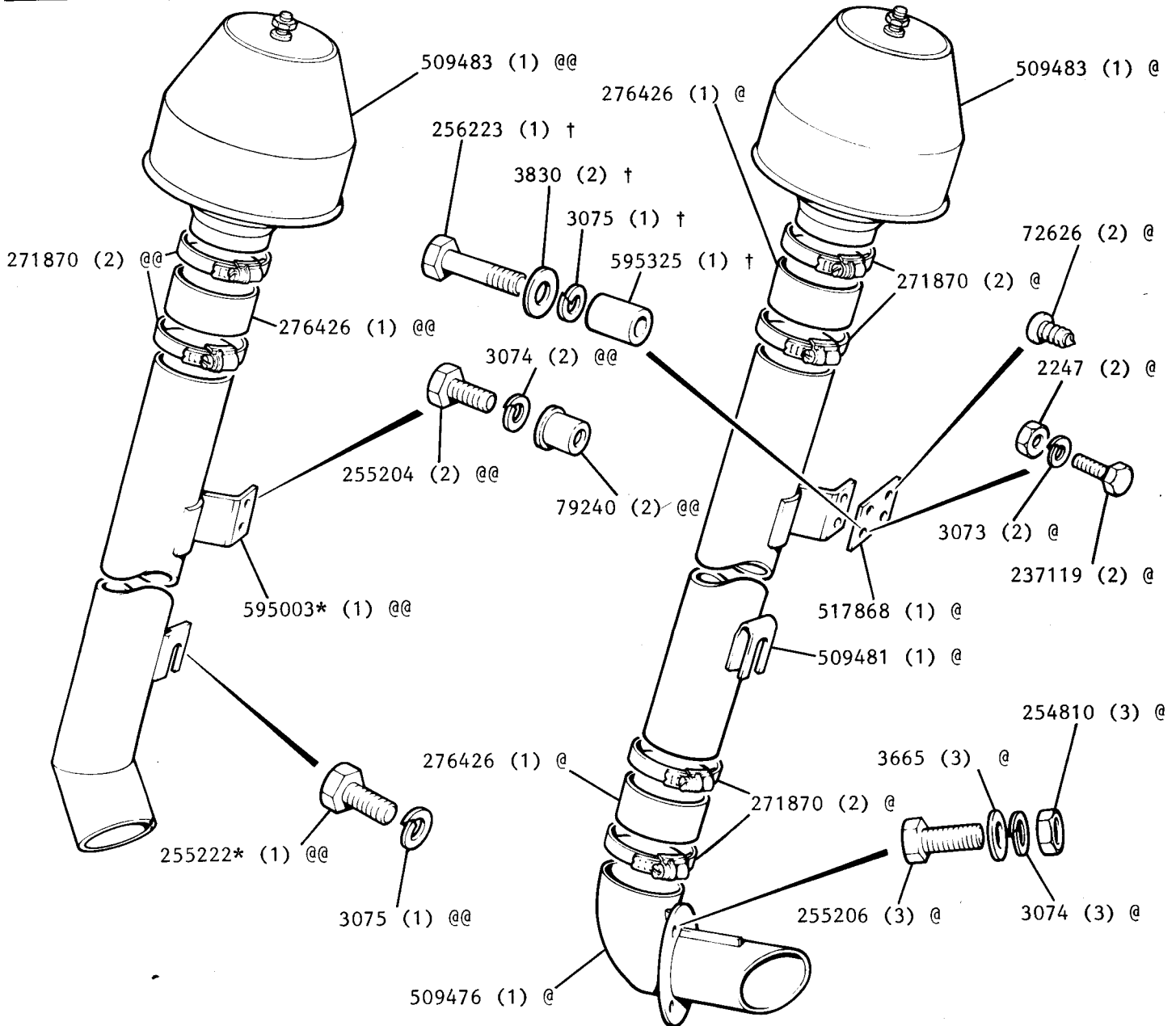

REMARKS

- Raised Air Intake Kit 517057 (1) @
- Raised Air Intake Kit 608156* (1) @@ 2½ petrol and diesel
- Raised Air Intake Kit 608154* (1) @@ 2.6 Petrol

@Series IIA

@@Series III

† To enable Series IIA Raised Air Intake Kit 517057 to be fitted to Series III 2½ R H Stg vehicles without servo and 2½ L H Stg vehicles without heater

CRANKCASE EMISSION CONTROL SERIES IIA 2¼ PETROL

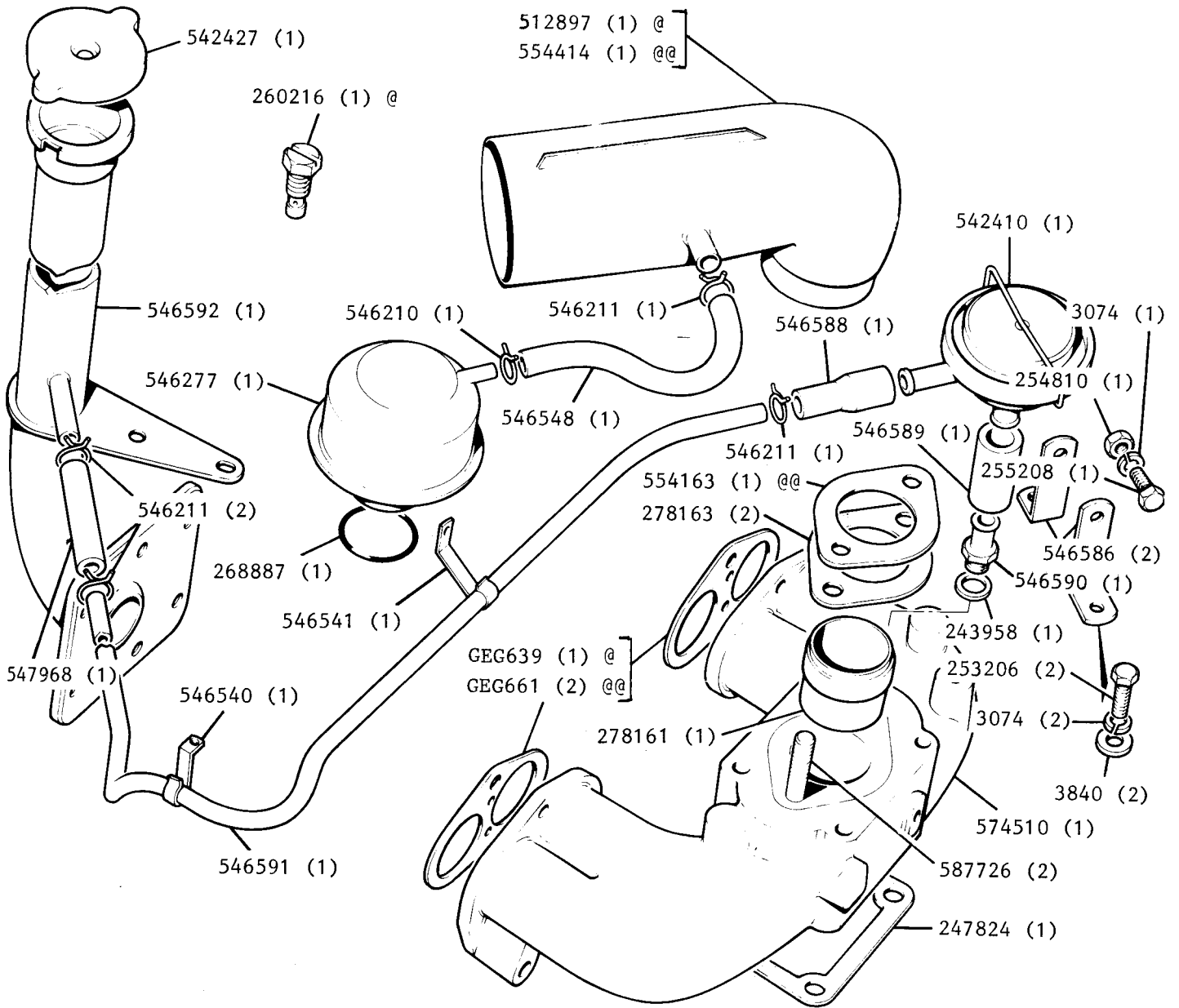

REMARKS

Crankcase Emission Control Kit 600493 (1) @
 Crankcase Emission Control Kit 601734 (1) @@

@ Up to engine suffix H inclusive
 @@ From engine suffix J onwards

CRANKCASE EMISSION CONTROL SERIES III

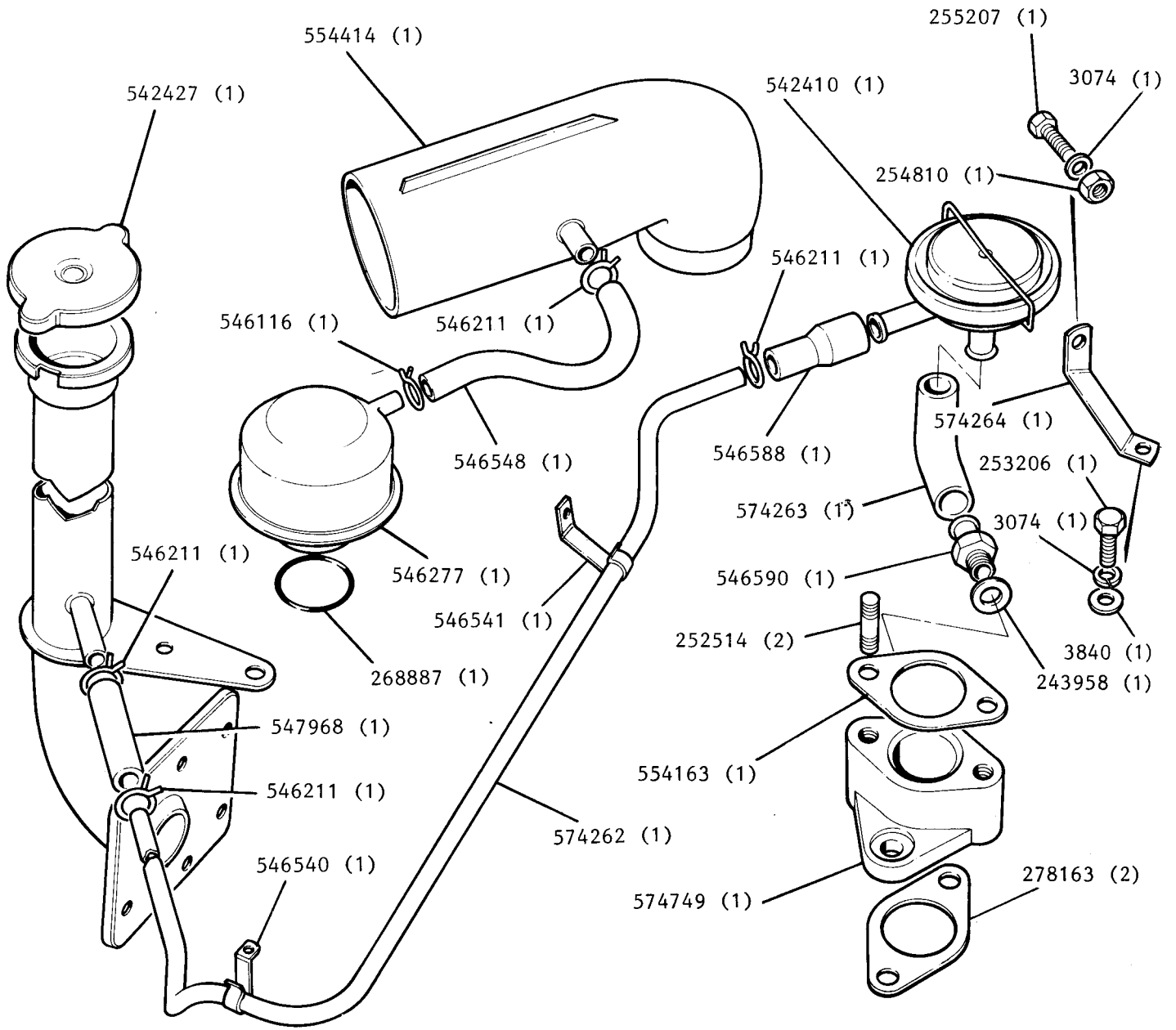

REMARKS

Crankcase Emission Control Kit 608385 (1)

DUST PROOFED ENGINE BREATHER SYSTEM SERIES IIA AND III 2½ PETROL

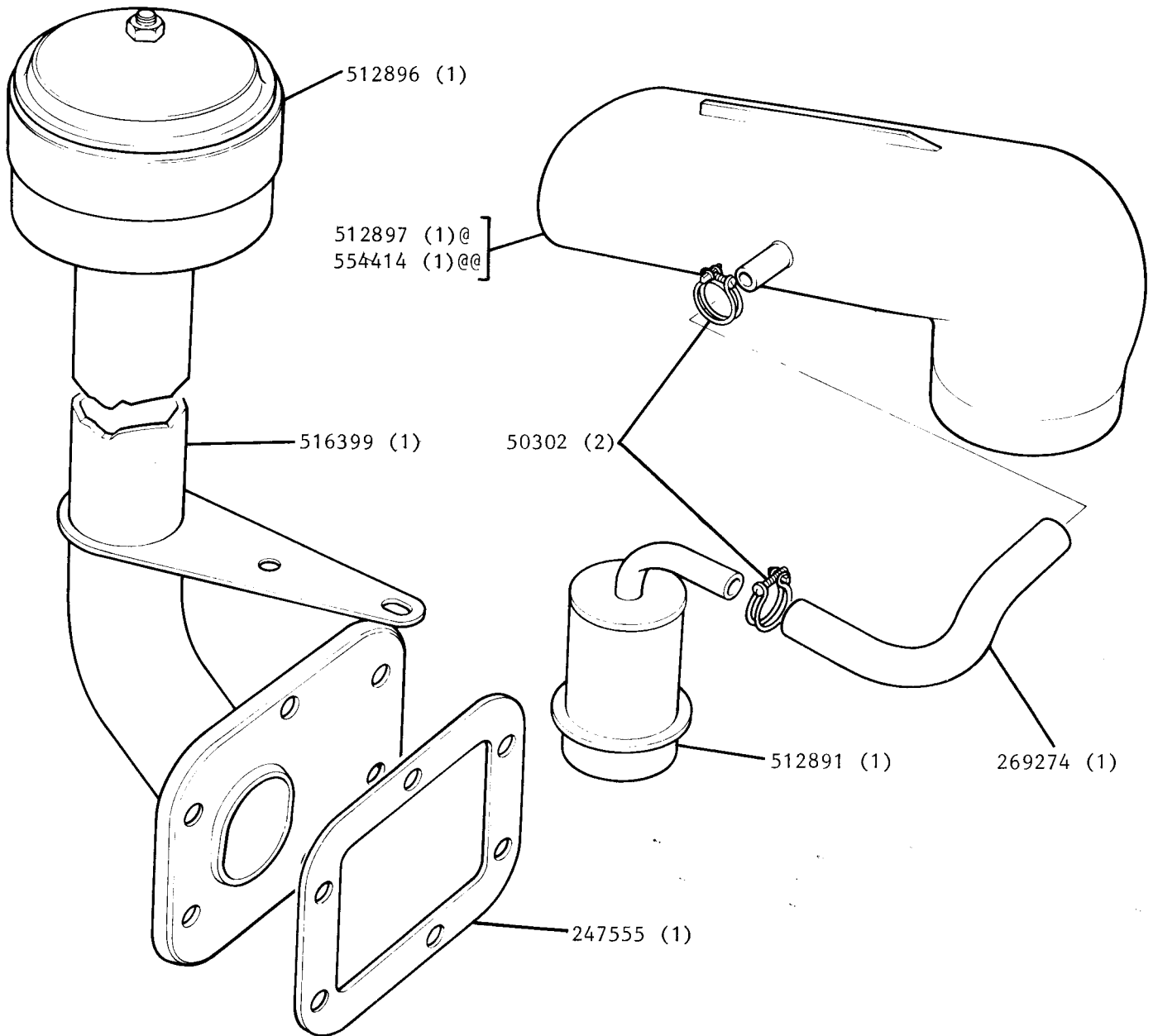

REMARKS

Dust Proofed Engine Breather Kit 517055 (1)@
Dust Proofed Engine Breather Kit 601732 (1)@@

@ Up to engine suffix 'H' inclusive

@@ From engine suffix 'J' onwards

VENTILATED FUEL PUMP VALVE BODY, SHIELD, AND TUBING SERIES IIA AND III 2.6 PETROL

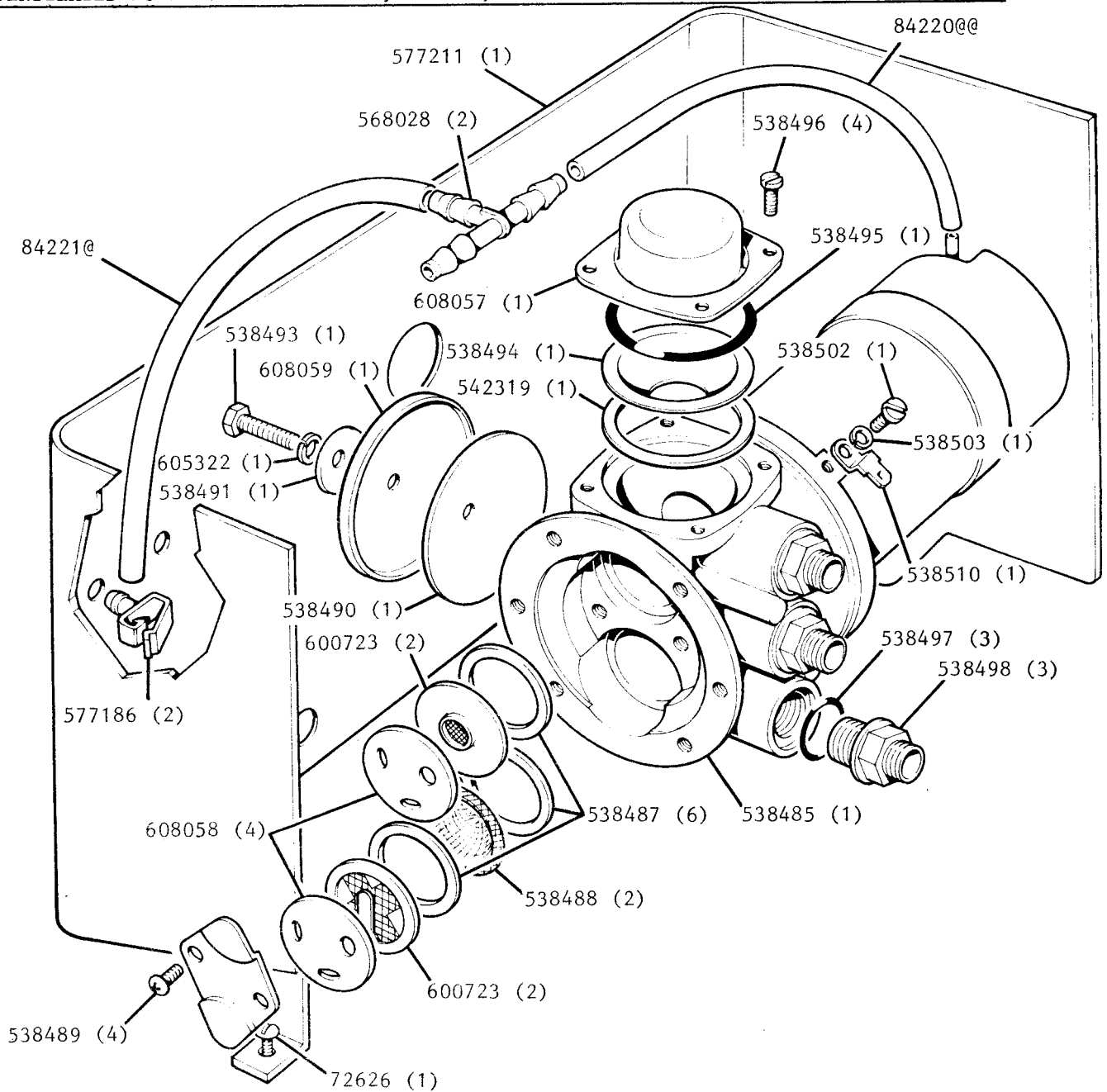

REMARKS

Fuel Pump complete 577203 (1)
 @ 14 inches long, makes 2 off
 @@ 24 inches long, makes 4 off

VENTILATED FUEL PUMP COIL, DIAPHRAGM AND PEDESTAL SERIES IIA AND III 2.6 PETROL

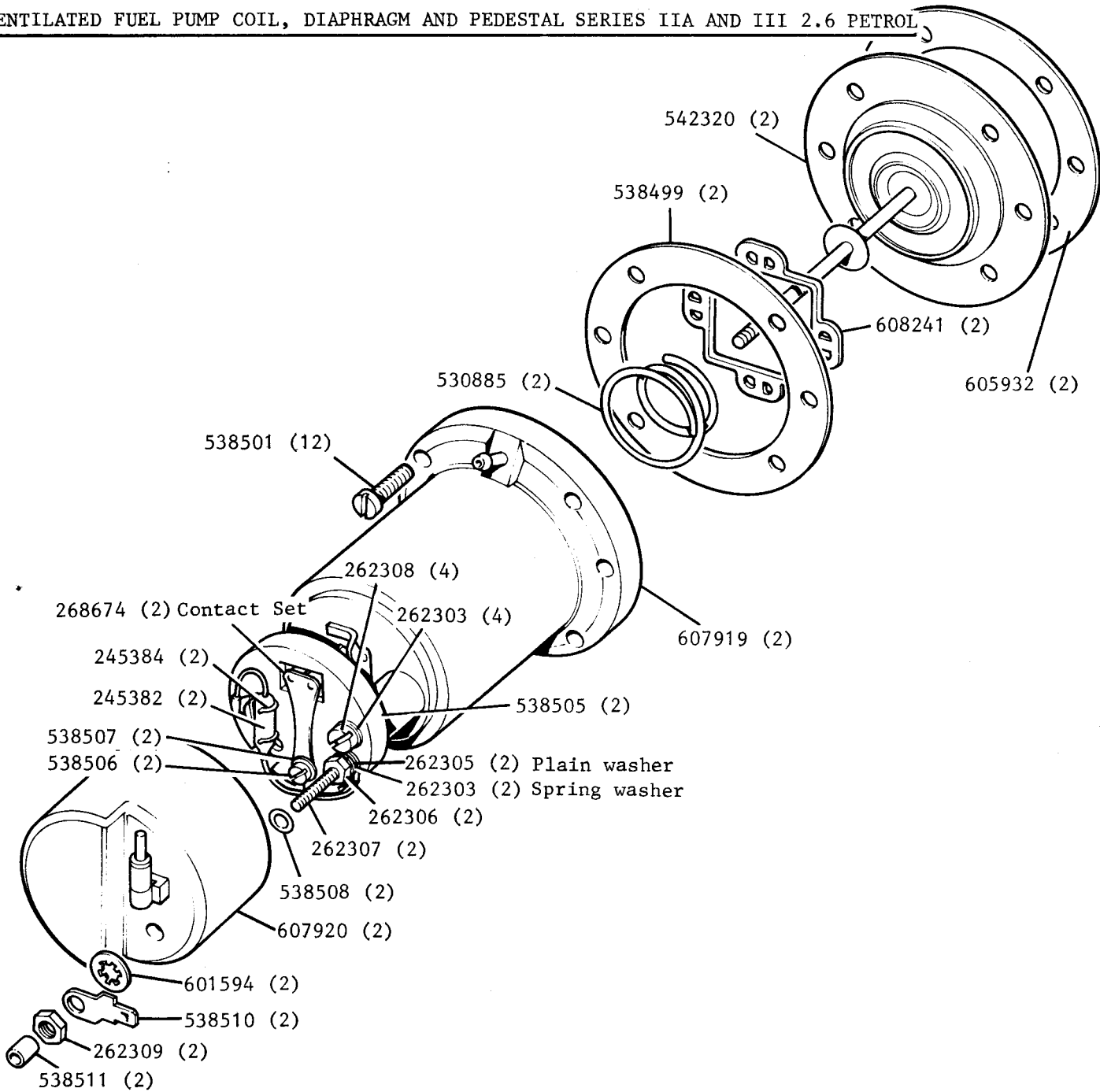

REMARKS

Fuel Pump Complete 577203 (1)

EXTRA FUEL FILTER SERIES 11A AND 111 DIESEL MODELS

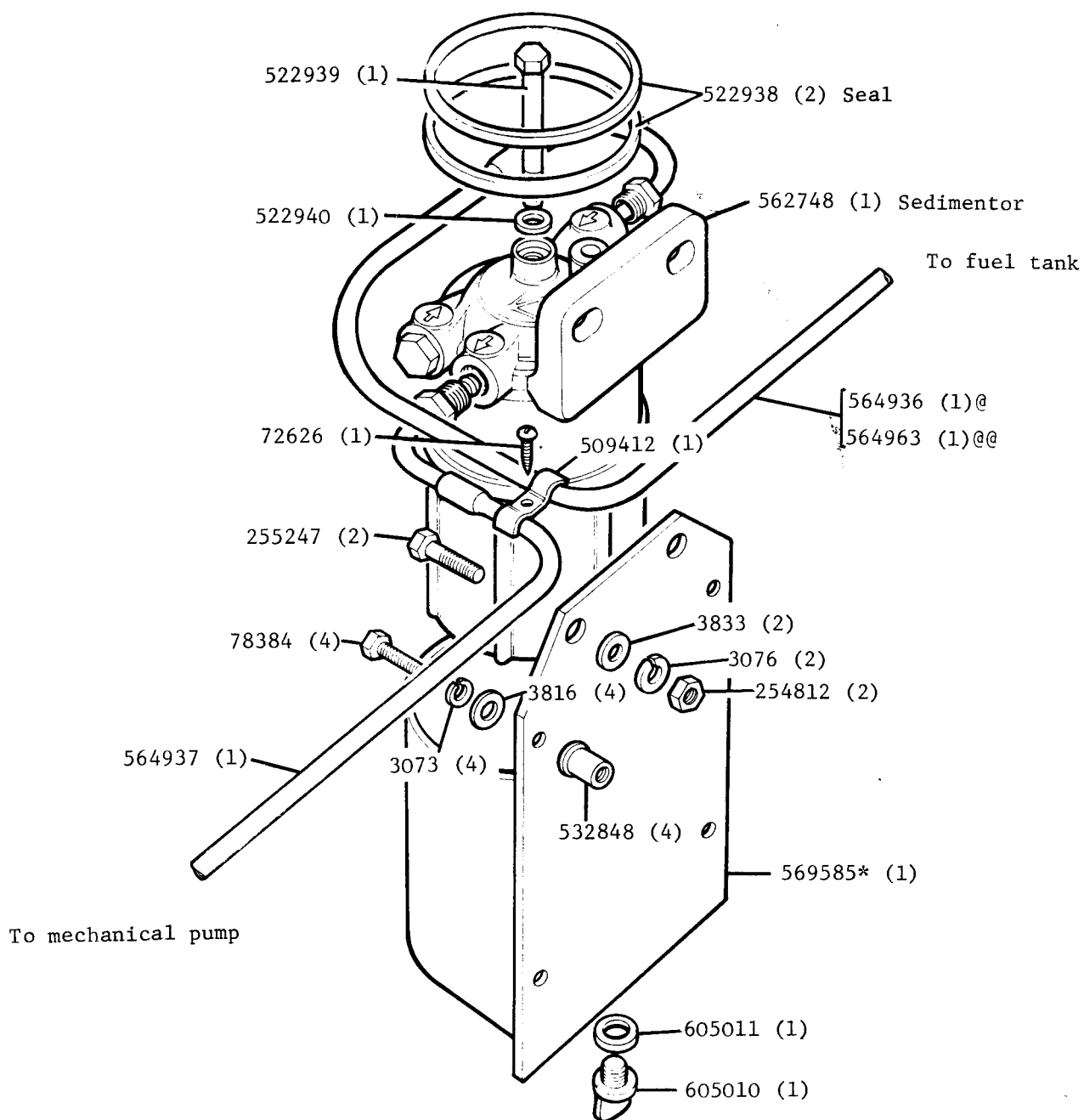

REMARKS

Sedimentor Complete Assembly 605560 (1)@ }
 Sedimentor Complete Assembly 605561 (1)@@ } Comprises all items on this frame.
 Standard fitting on all export models, optional for home market models.
 @ 88in and 109in long 2¼ litre diesel models
 @@ 109in Station Wagon 2¼ litre diesel

AUXILIARY FUEL TANK COVER PANEL, TANK AND FIXINGS SERIES IIA AND III 109 in. 2.6

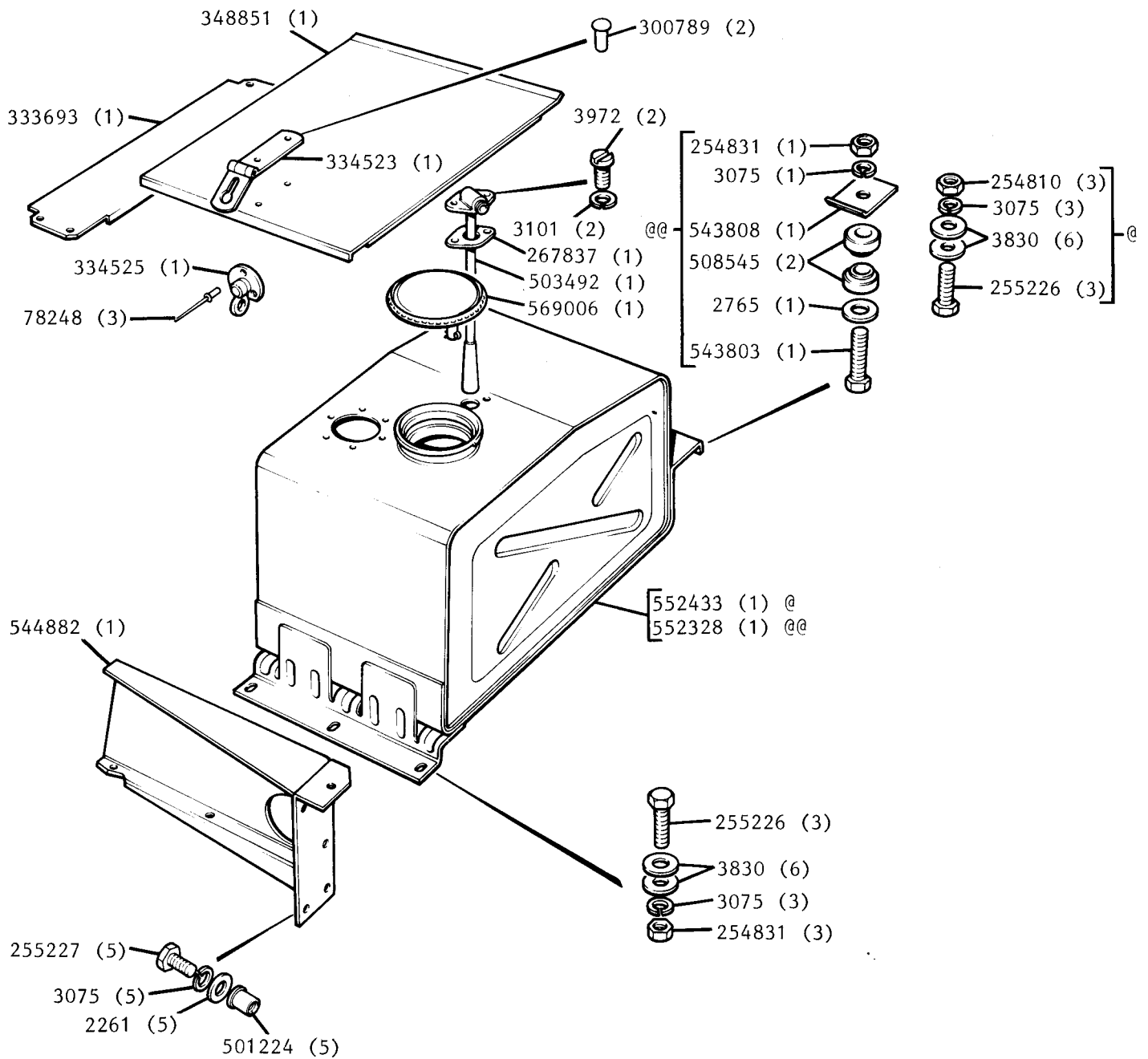

REMARKS

@ Three fixings at rear of tank

@@ One fixing at rear of tank

Auxiliary Fuel Tank Kit 605401 Series IIA

Auxiliary Fuel Tank Kit 607806 Series III

AUXILIARY FUEL TANK TWO WAY COCK, PIPES AND GAUGE UNIT, SERIES IIA AND III 109 in 2.6,

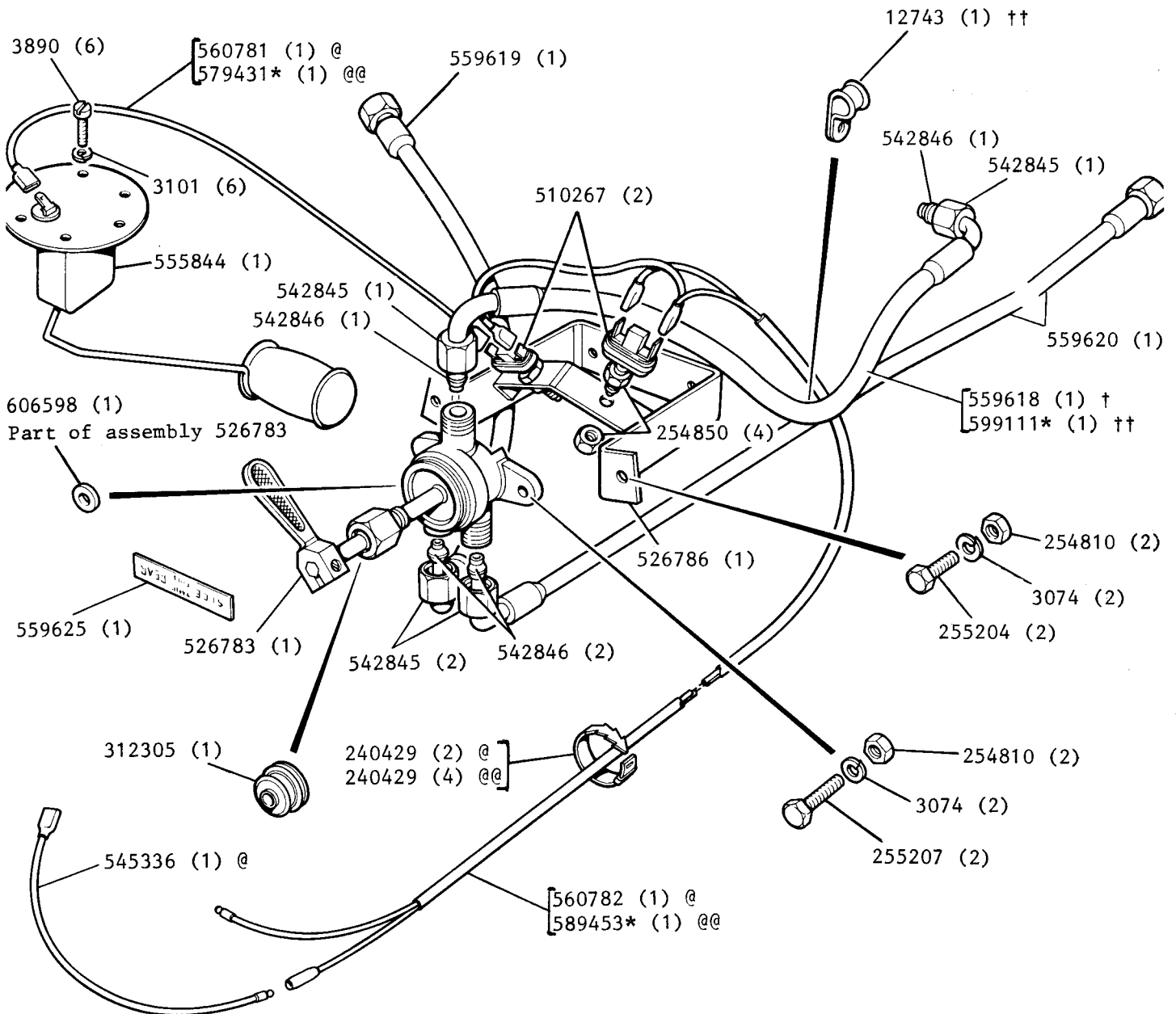

REMARKS

Auxiliary Fuel Tank Kit 605401 @
 Auxiliary Fuel Tank Kit 607806 @@
 @ Series IIA
 @@ Series III

† When twin S.U. fuel pump is fitted
 †† When Bendix fuel pump is fitted

REAR AND CENTRE POWER TAKE-OFF GEARBOX UNIT ASSEMBLY
SERIES IIA AND III 88 in AND 109 in EXCEPT 109 in STATION WAGON

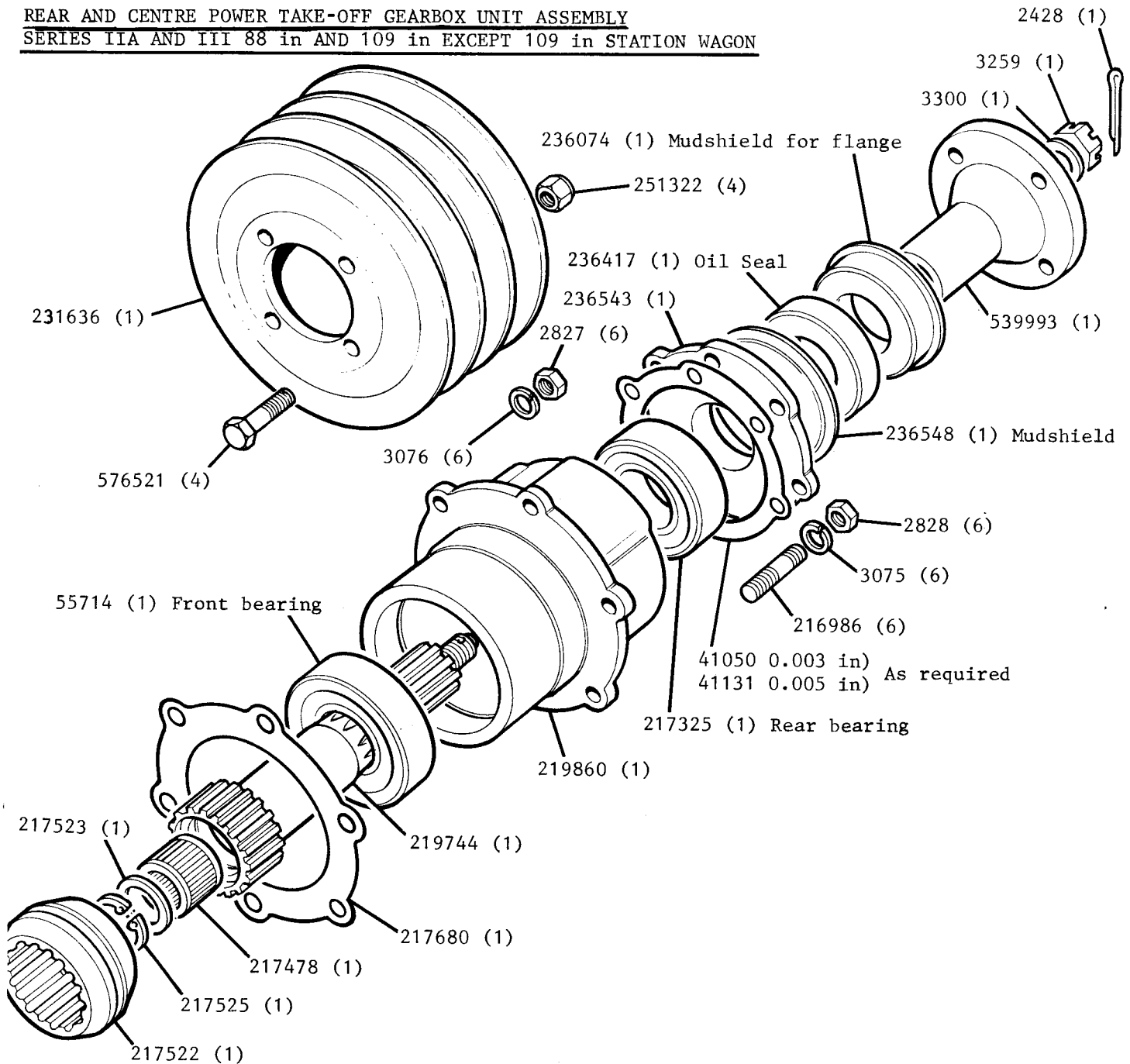

REMARKS

Power Take-Off Gearbox Unit Assembly 230855 (1)
Rear Power Take-Off Kit 241706 (1) 88 in)
Rear Power Take-Off Kit 501680 (1) 2¼) Series IIA) Must be used
Rear Power Take-Off Kit 605352 (1) 2.6) 109 in) in conjunction
Rear Power Take-Off Kit 606876* (1) 88 in)) with towing
Rear Power Take-Off Kit 606877* (1) 2¼)) equipment
Rear Power Take-Off Kit 606891* (1) 2.6) Series III) 501683 for
) 2¼ models and
) 2.6 models
Centre Power Take-Off Kit 261835 (1) 2¼)
Centre Power Take-Off Kit 605928 (1) 2.6) Less Centre Pulley

REAR AND CENTRE POWER TAKE-OFF SELECTOR UNIT
SERIES 11A AND 111 88in AND 109in EXCEPT 109in STATION WAGON

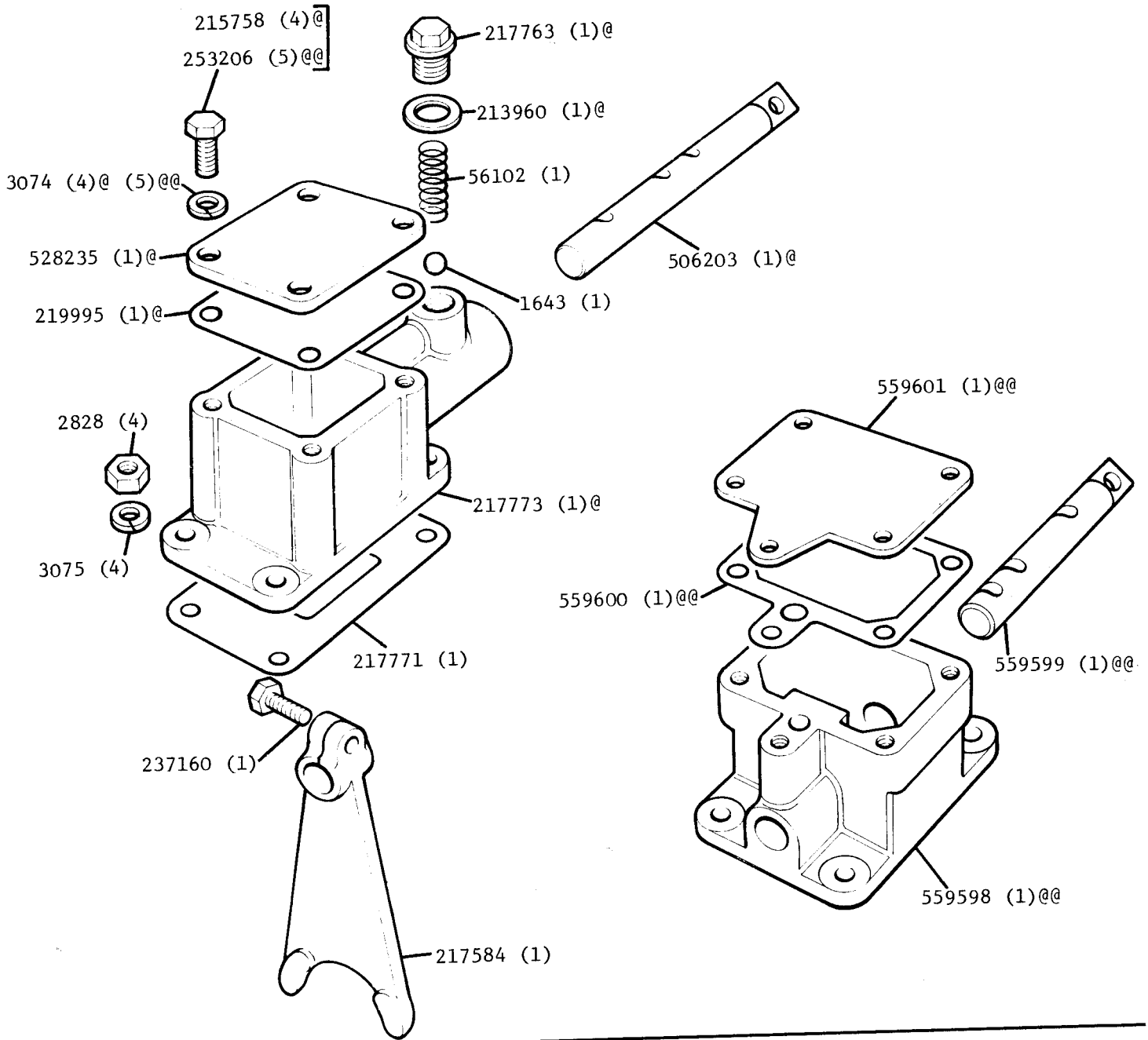

REMARKS

Power Take-Off Selector Unit Assembly 509076 (1)@
 Power Take-Off Selector Unit Assembly 559597 (1)@@
 @ 2¼ Litre Models
 @@ 2.6 Litre Models
 For rear and centre power take-off kit part numbers see
 frame 25 15

REAR AND CENTRE POWER TAKE-OFF SELECTOR ROD AND LEVER FOR SERIES 11A AND 111 88in AND 109in
EXCEPT 109in STATION WAGON

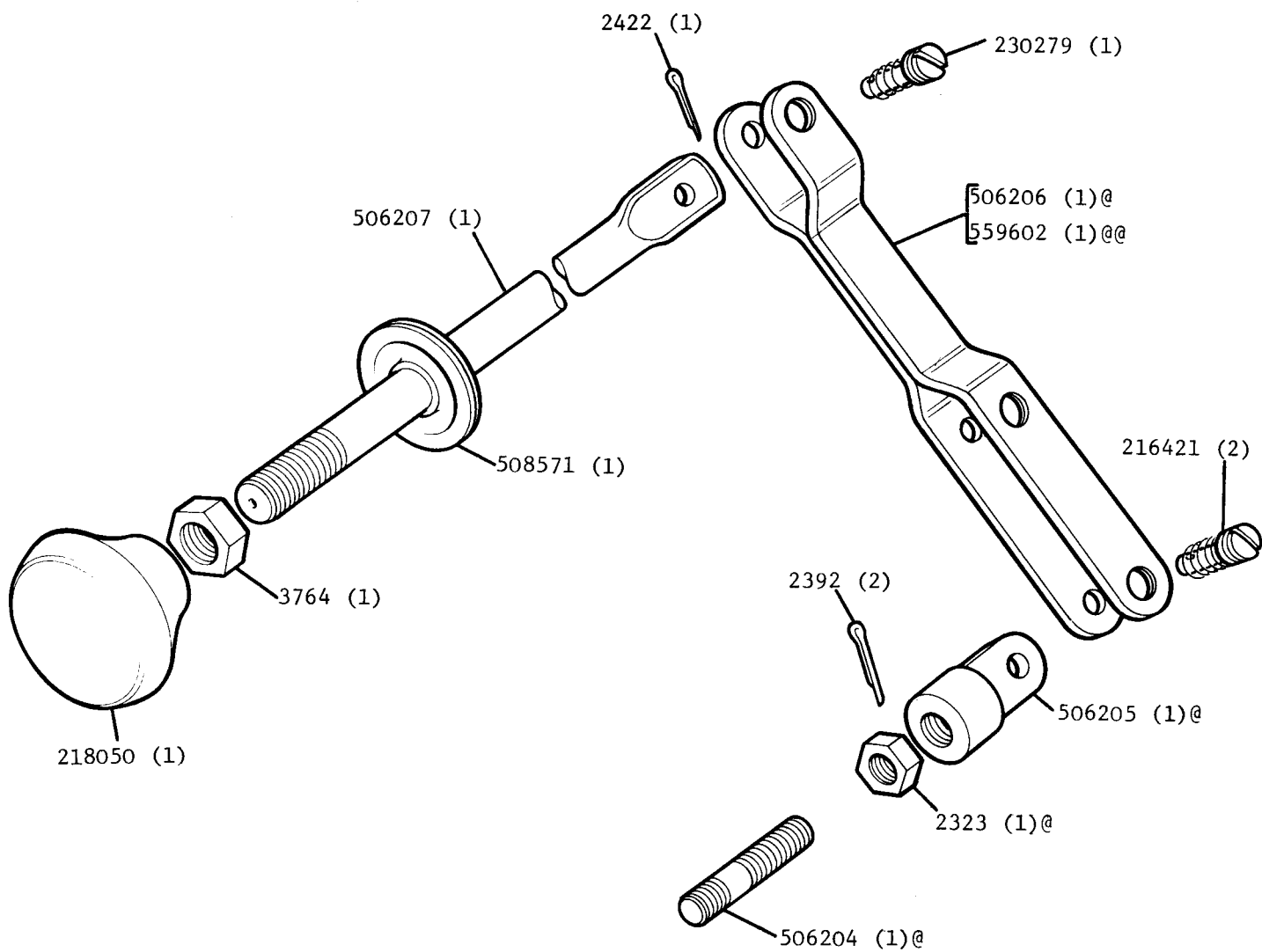

REMARKS

@ 2½ litre models

@@ 2.6 litre Models

For rear and centre power take-off kit part numbers see
frame 25 15

88in PROPELLOR SHAFT, 109in FRONT PROPELLOR SHAFT AND INTERMEDIATE SUPPORT BRACKET. SERIES 11A AND 111 EXCEPT 109in STATION WAGON

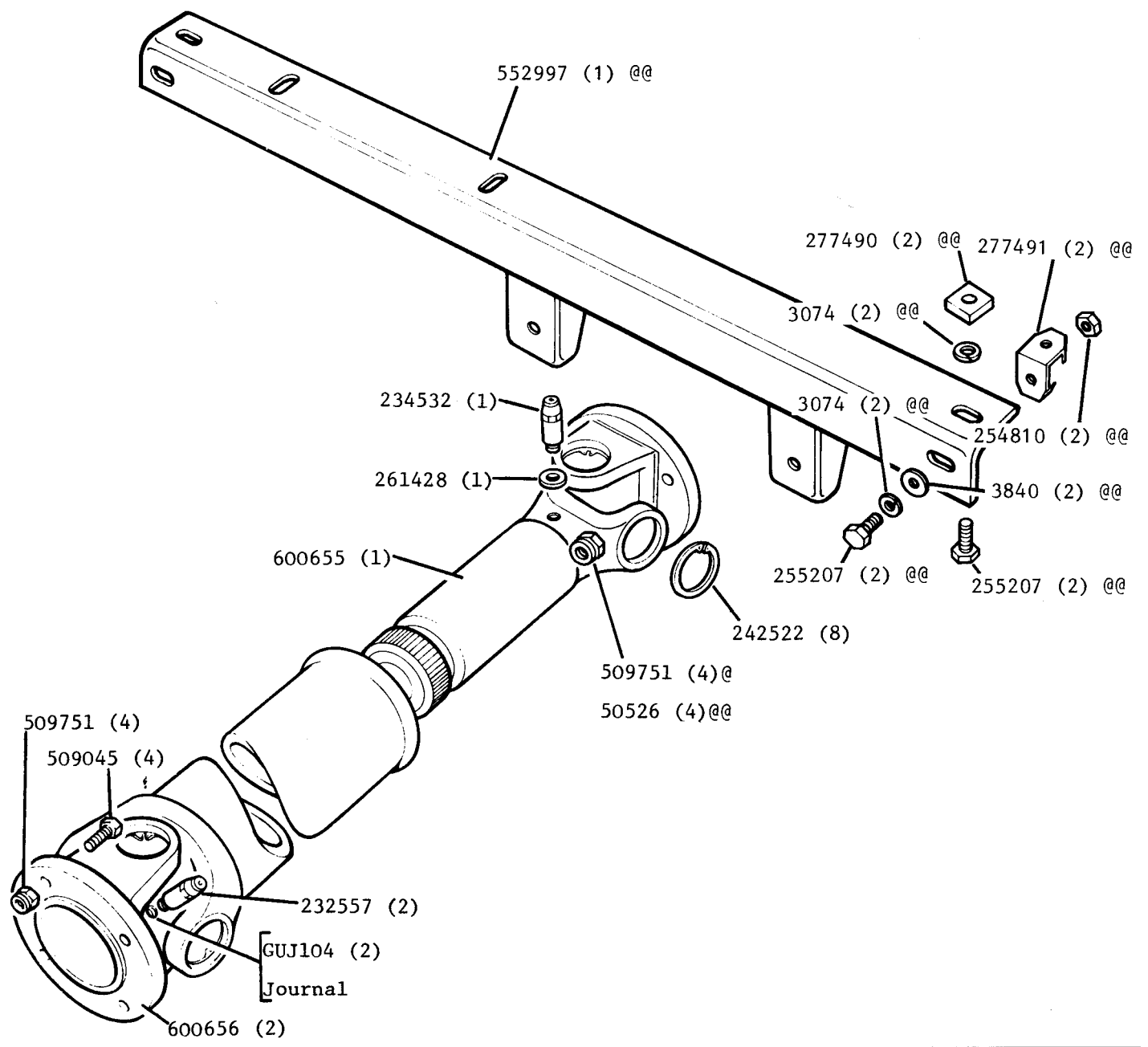

REMARKS

Propellor shaft 533728 2¼ litre models
 Propellor shaft 559564 2.6 litre Models

@ 88in.

@@ 109 in.

For rear and centre power take-off kit part numbers see frame 25 15

REAR POWER TAKE-OFF REAR PROPELLOR SHAFT SERIES 11A and 111 109in.
 EXCEPT STATION WAGON

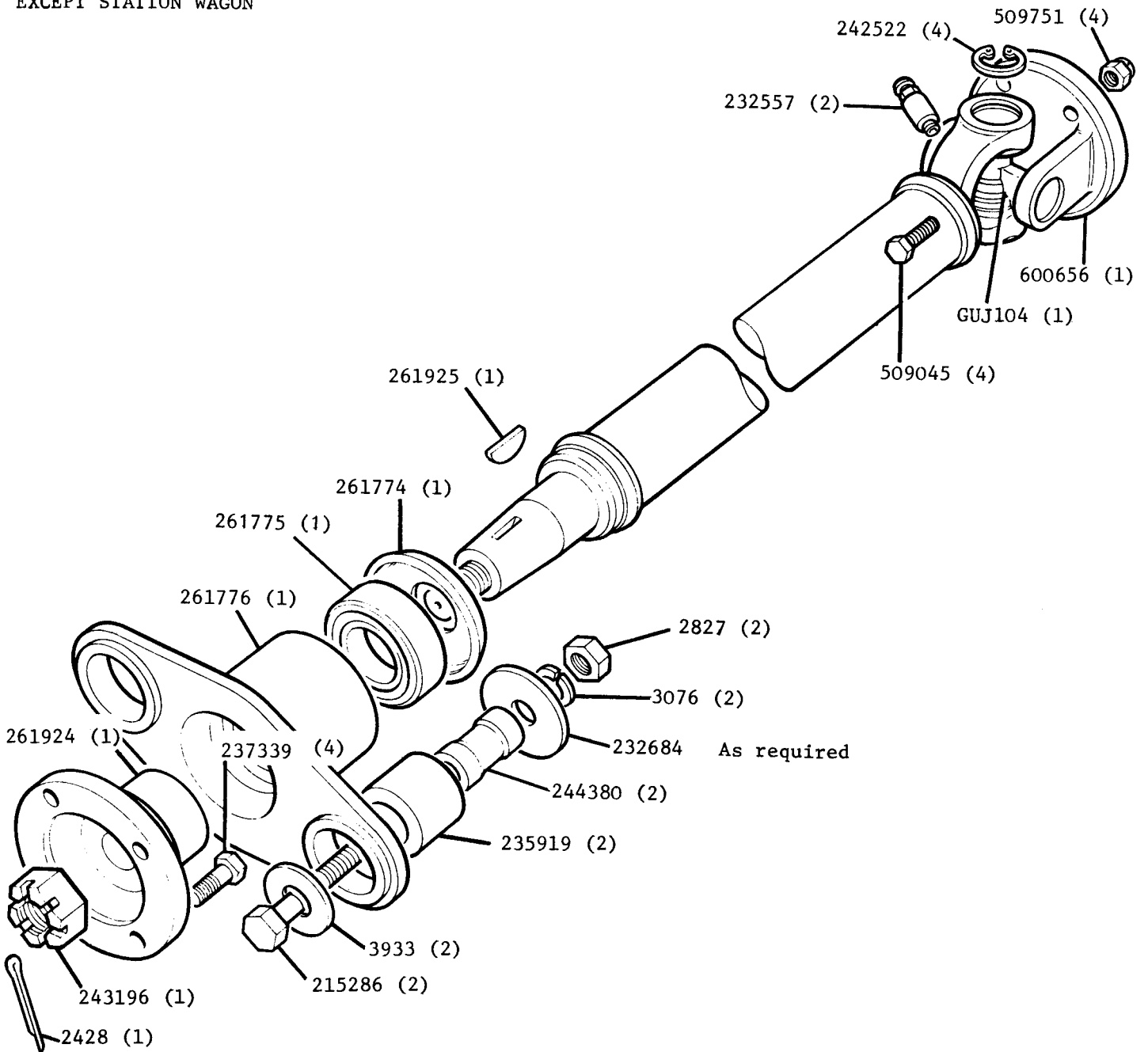

REMARKS

Propellor Shaft Assembly 533727 (1) Comprises all items on this frame.
 For rear and centre power take-off kit part numbers see
 frame 25 15

REAR POWER TAKE-OFF DRIVE SECTION. SERIES 11A AND 111
88in AND 109in EXCEPT 109in STATION WAGON

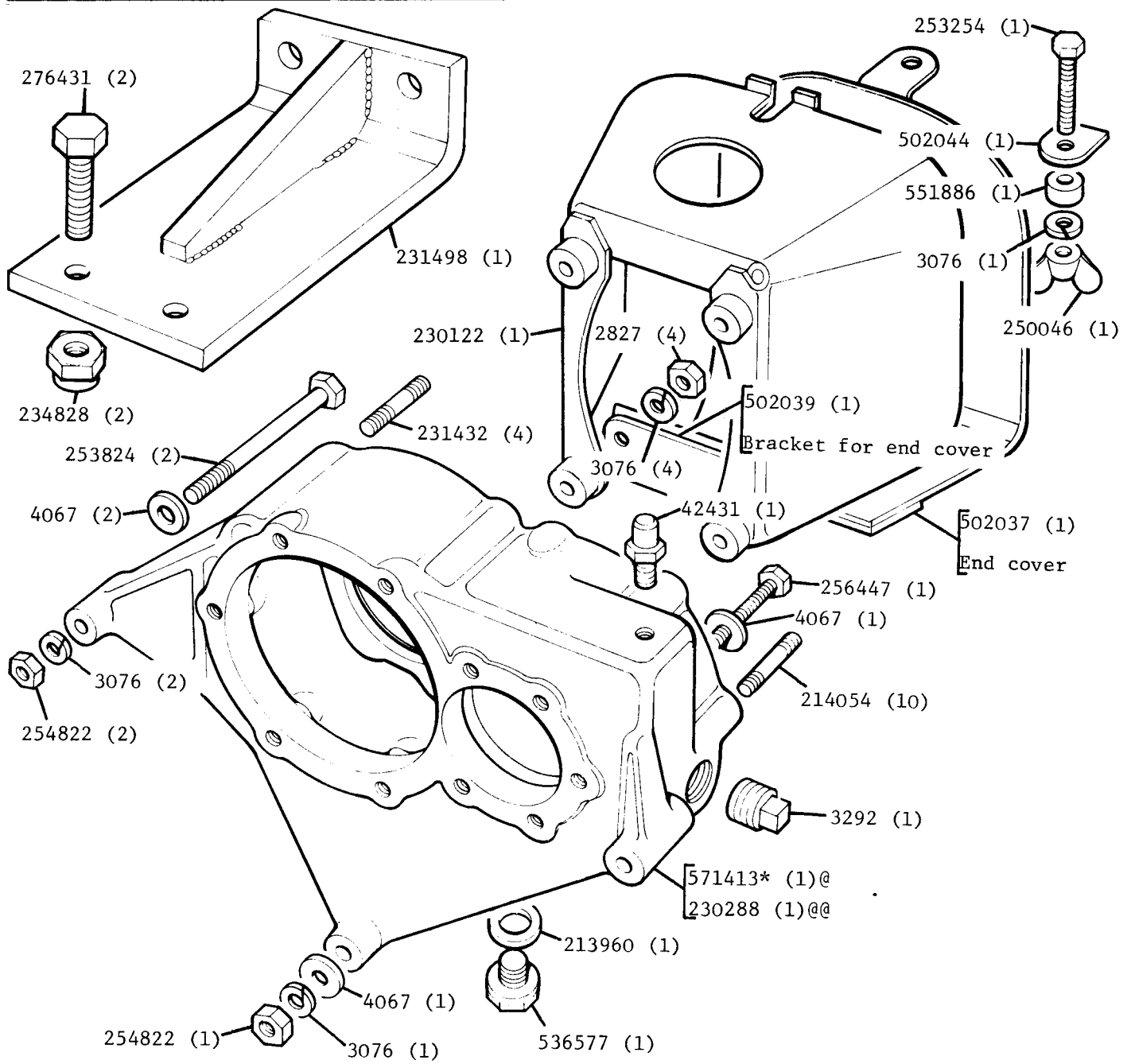

REMARKS

Power take-off drive section 1.389:1 ratio 571410* (1)@

Power take-off drive section 1.2:1 ratio 230176 (1)@@

@ Series 111 Land Rover

@@ Series 11A Land Rover

For rear and centre power take-off kit part numbers see
frame 25 15

INPUT SHAFT FOR REAR POWER TAKE-OFF DRIVE SECTION
SERIES 11A AND 111 88in AND 109in EXCEPT 109in STATION WAGON

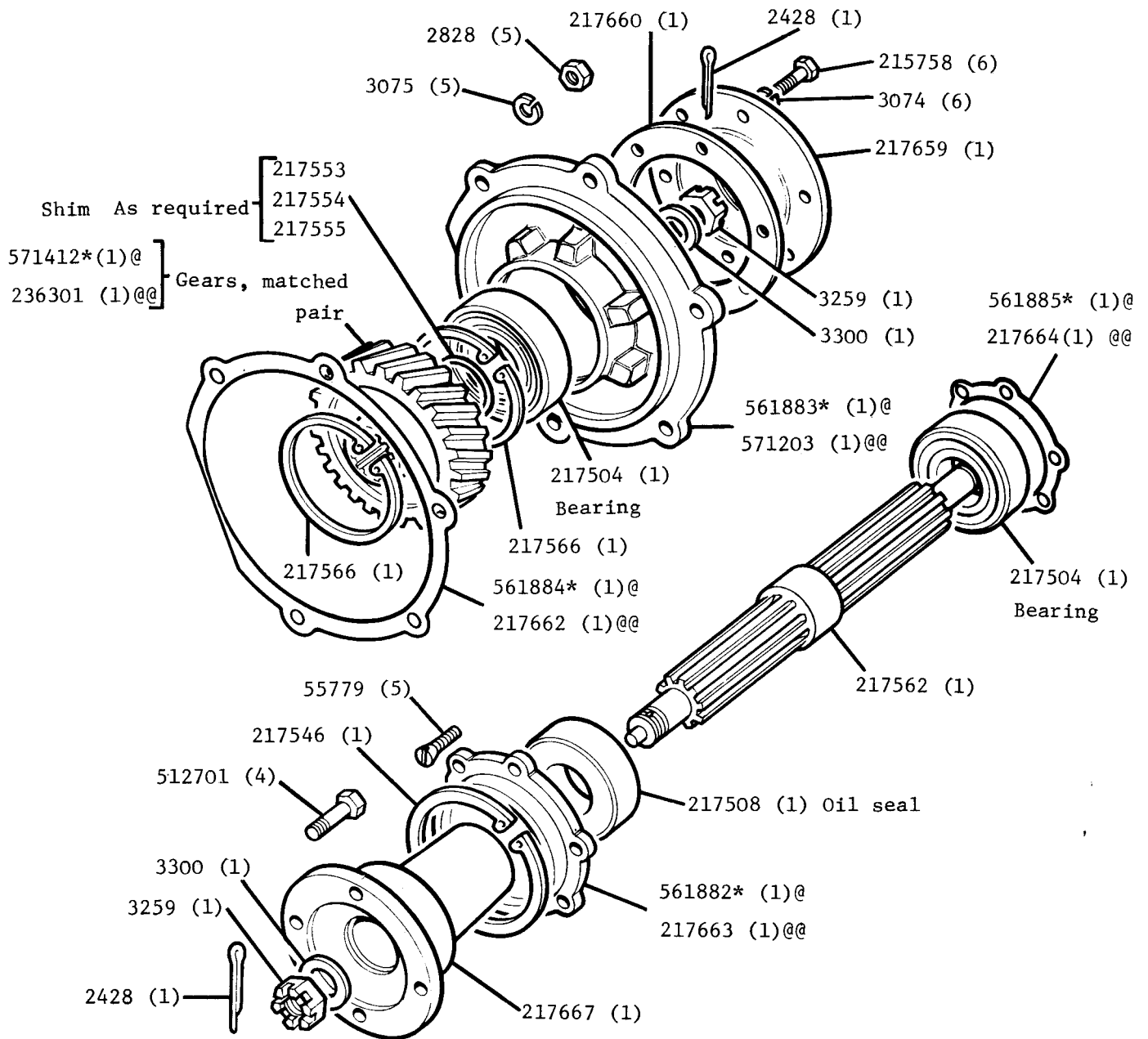

REMARKS

Power take-off drive section 1.389: 1 ratio 571410*(1)@

Power take-off drive section 1.2:1 ratio 230176 (1)@@

@ Series 111 Land Rover

@@ Series 11A Land Rover

For rear and centre power take-off kit part numbers see
 frame 25 15

OUTPUT SHAFT FOR REAR POWER TAKE-OFF DRIVE SECTION
SERIES 11A AND 111 88in AND 109in EXCEPT 109in STATION WAGON

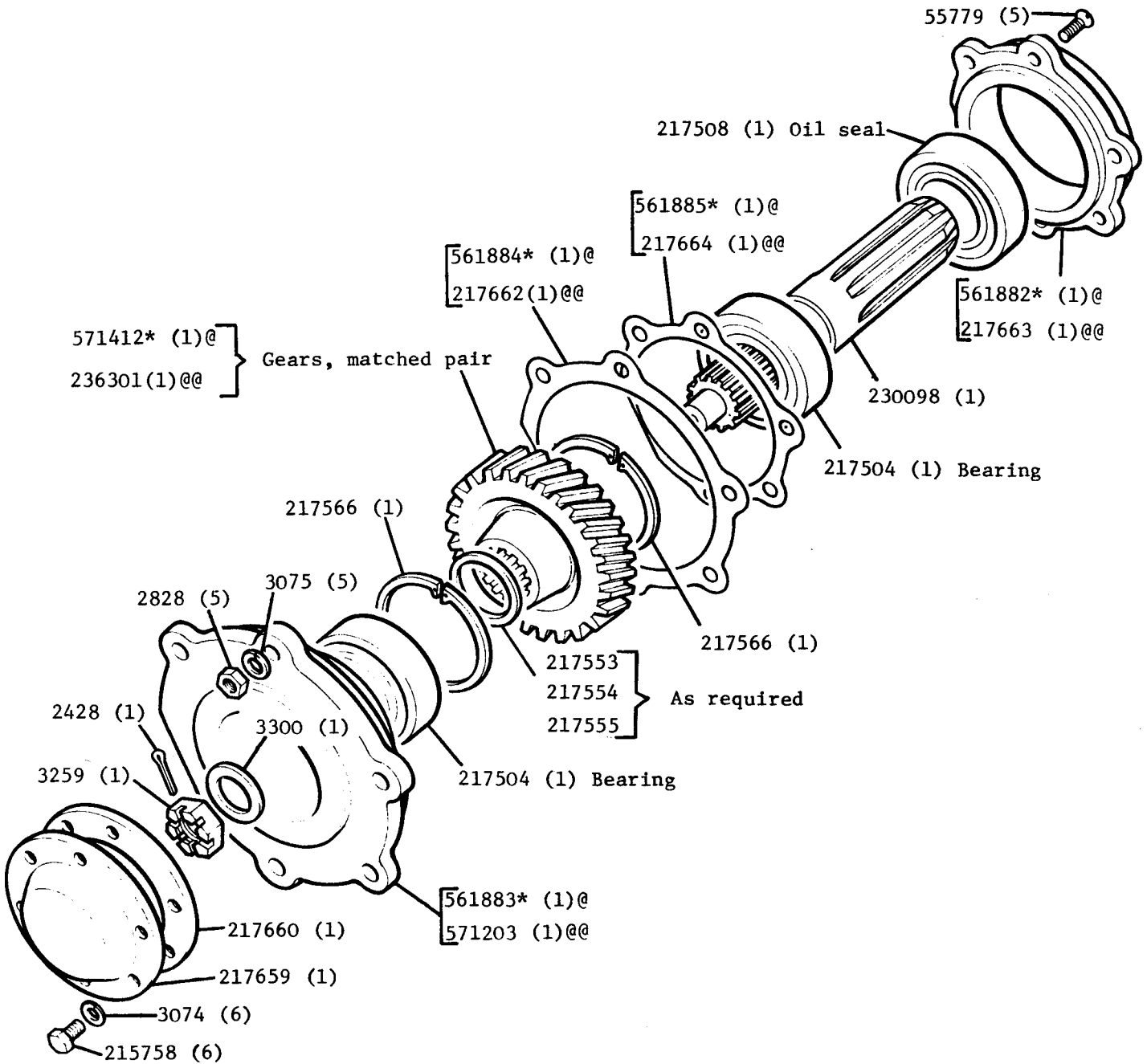

REMARKS

Power take-off drive section 1.389:1 ratio 571410 *(1)@
 Power take-off drive section 1.2:1 ratio 230176 (1)@@
 @ Series 111 Land Rover
 @@ Series 11A Land Rover
 For rear and centre power take-off kit part numbers see
 frame 25 15

REAR POWER TAKE-OFF PULLEY SECTION

SERIES IIA AND III 88in AND 109 in EXCEPT 109 in STATION WAGON

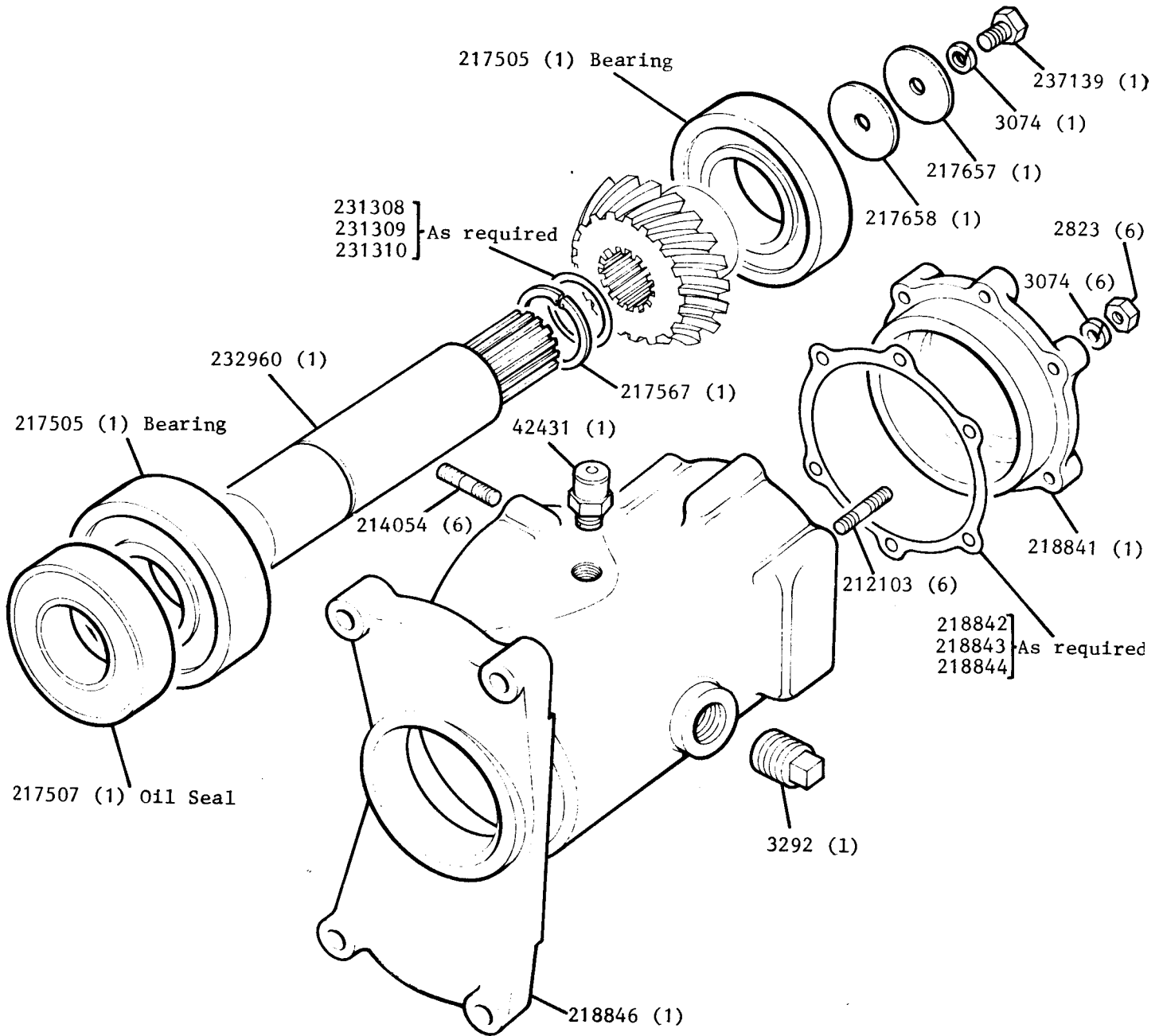

REMARKS

Power take-off assembly pulley section 230177 (1)
For rear and centre power take-off kit part numbers see
frame 25 15

REAR POWER TAKE-OFF PULLEY SECTION. SERIES 11A AND 111 88in AND 109in
EXCEPT 109in STATION WAGON

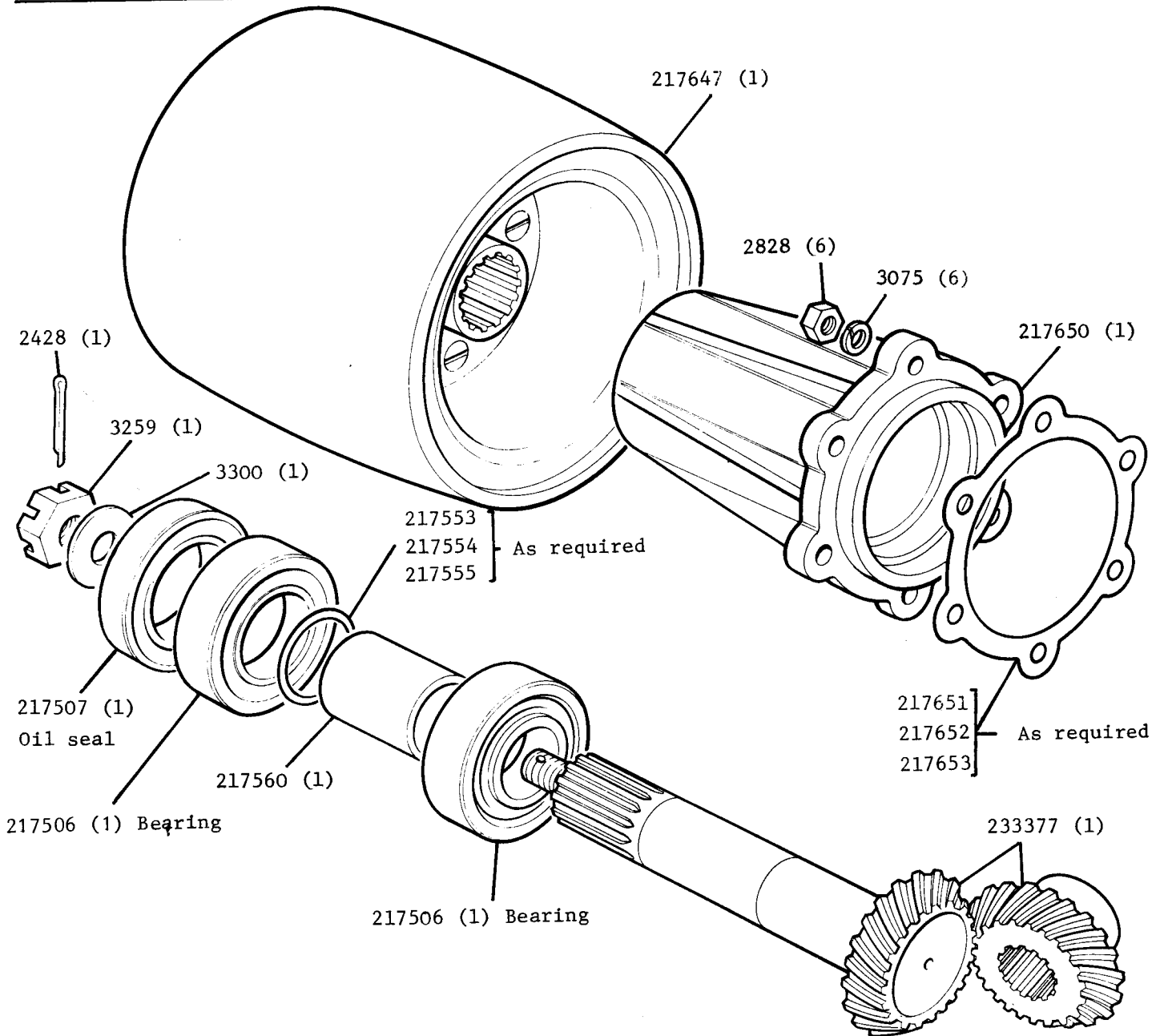

REMARKS

Power Take-off Assembly, pulley section 230177 (1)
 For rear and centre power take-off kit part numbers see
 frame 25 15

UNDERSHIELD, GEARBOX, SERIES IIA AND III 109 in.

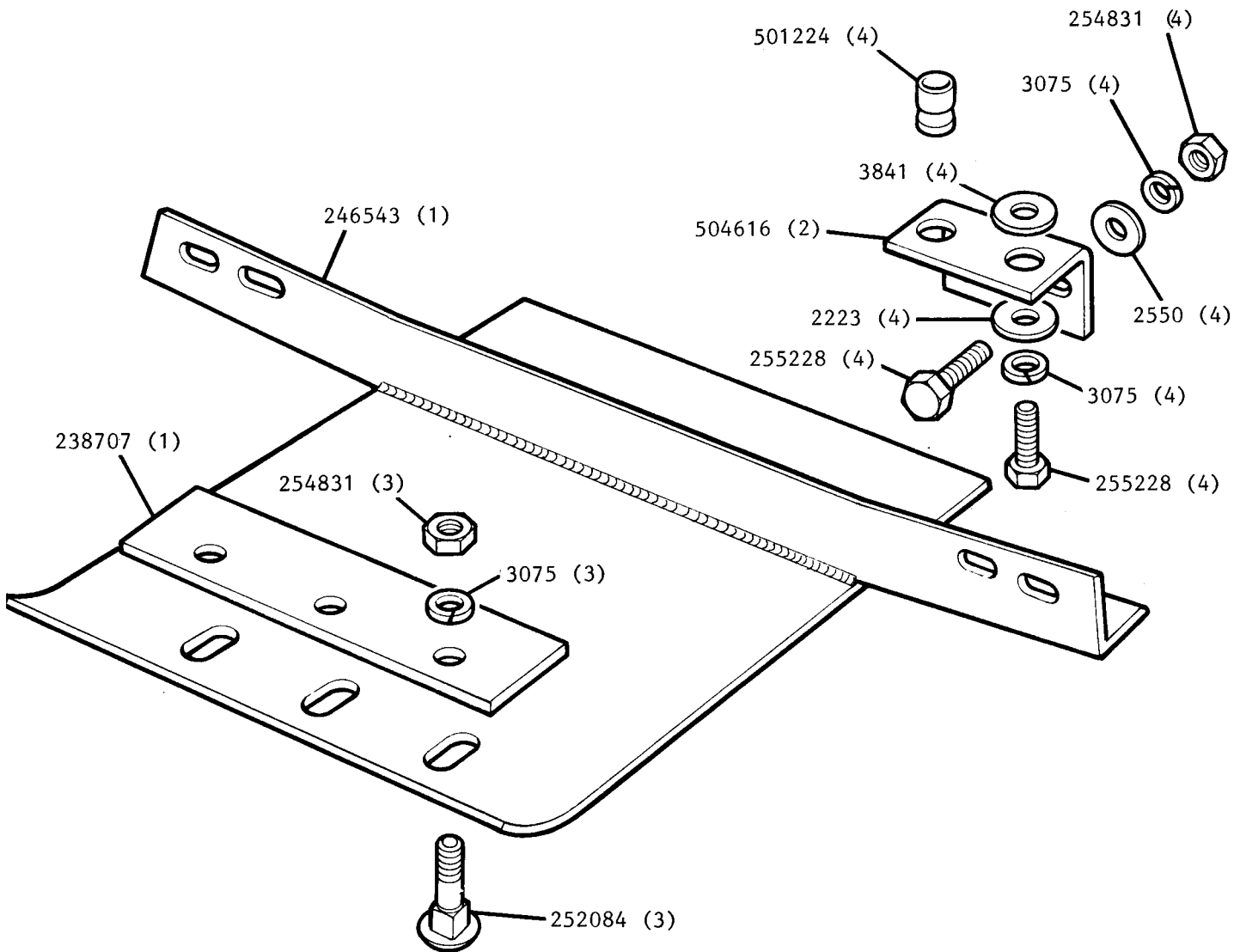

REMARKS

Undershield Kit. 607738* (1) Fitted as standard to 109 in vehicles for Switzerland.

STEERING COLUMN LOCK SERIES IIA LH STG PETROL MODELS FROM JUNE 1968 ONWARDS

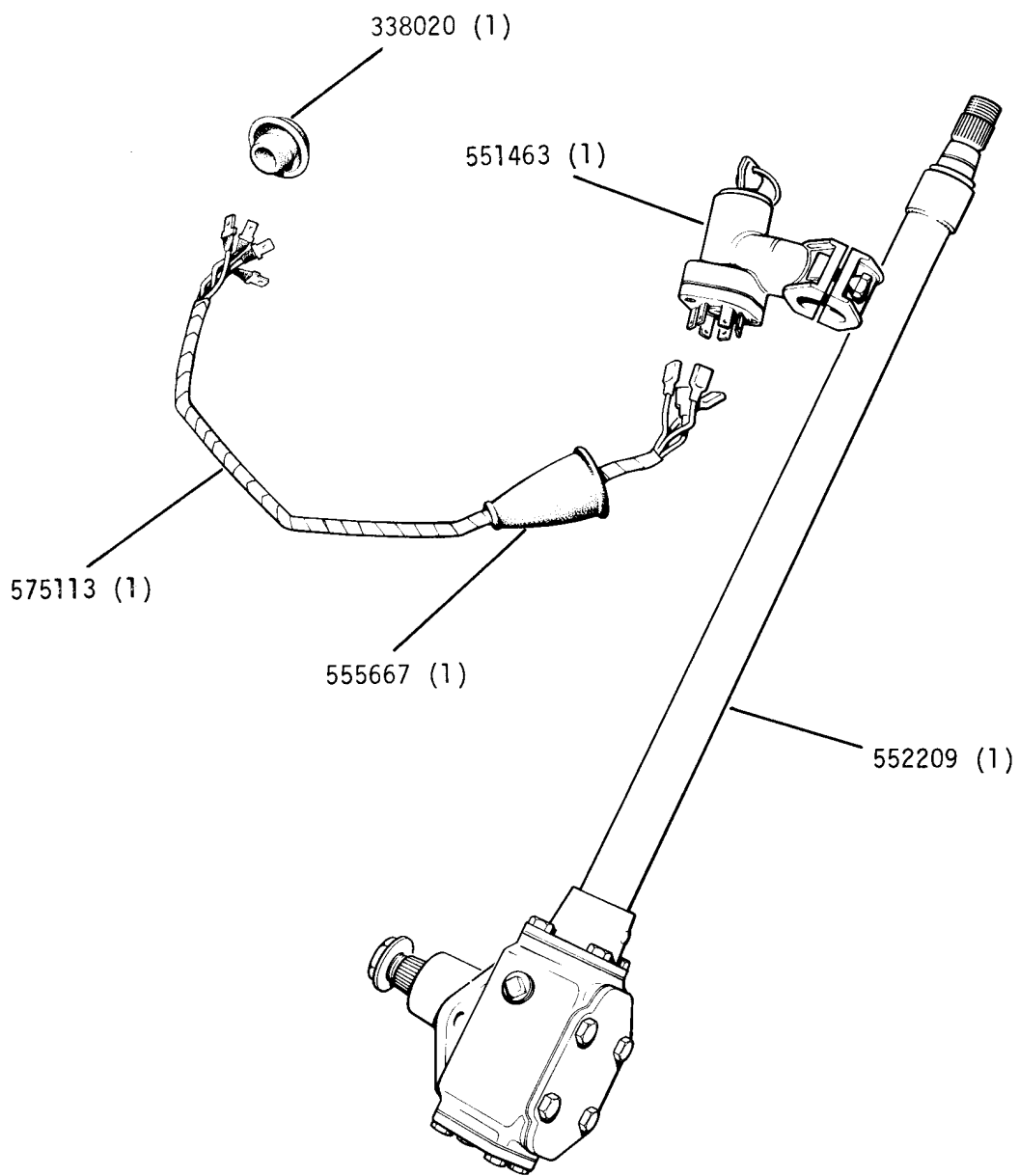

REMARKS

STEERING COLUMN LOCK SERIES III

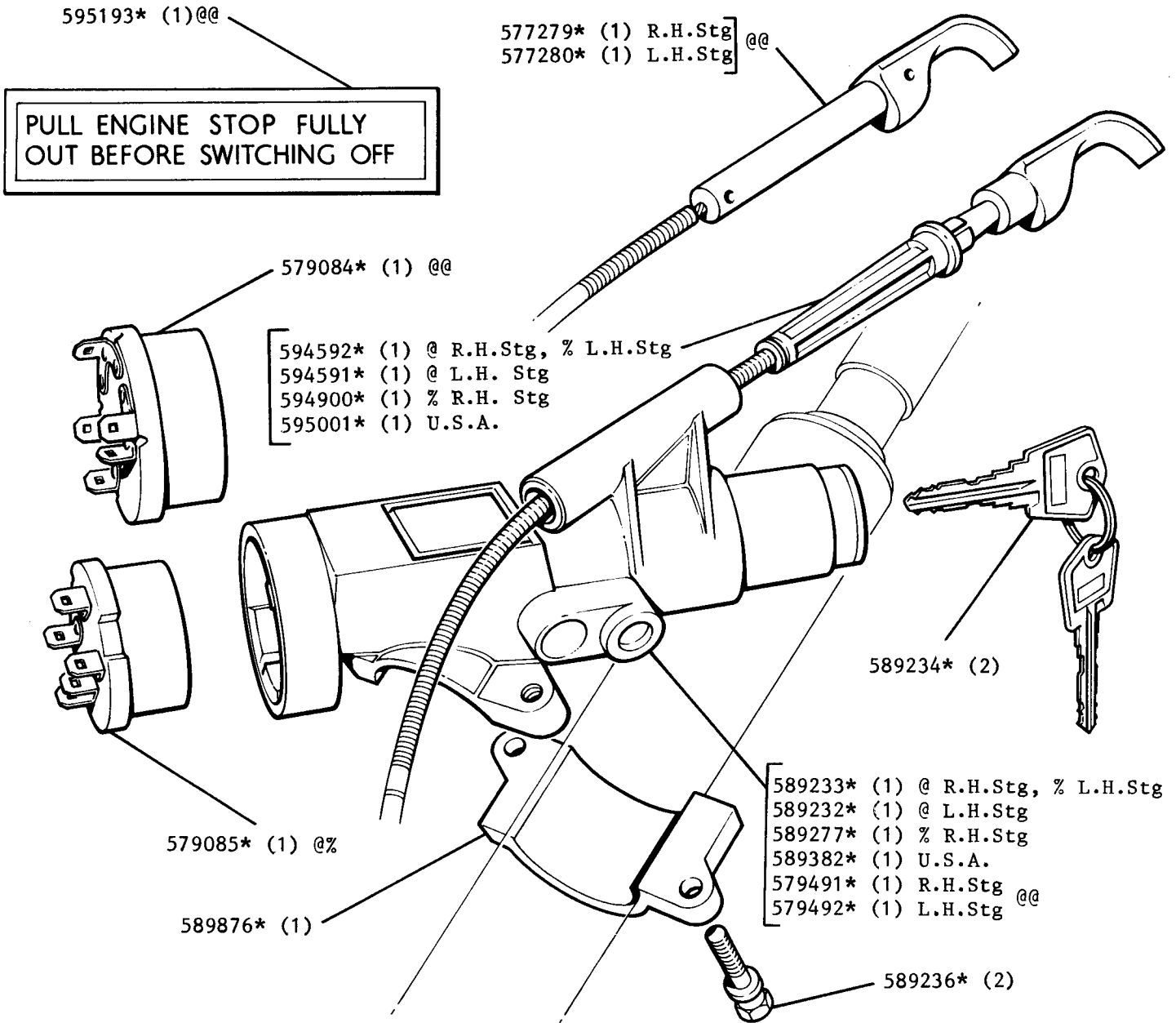

REMARKS

- @ 2½ petrol
- @@ 2½ diesel
- % 2.6 petrol

STEERING DAMPER SERIES 11A AND 111

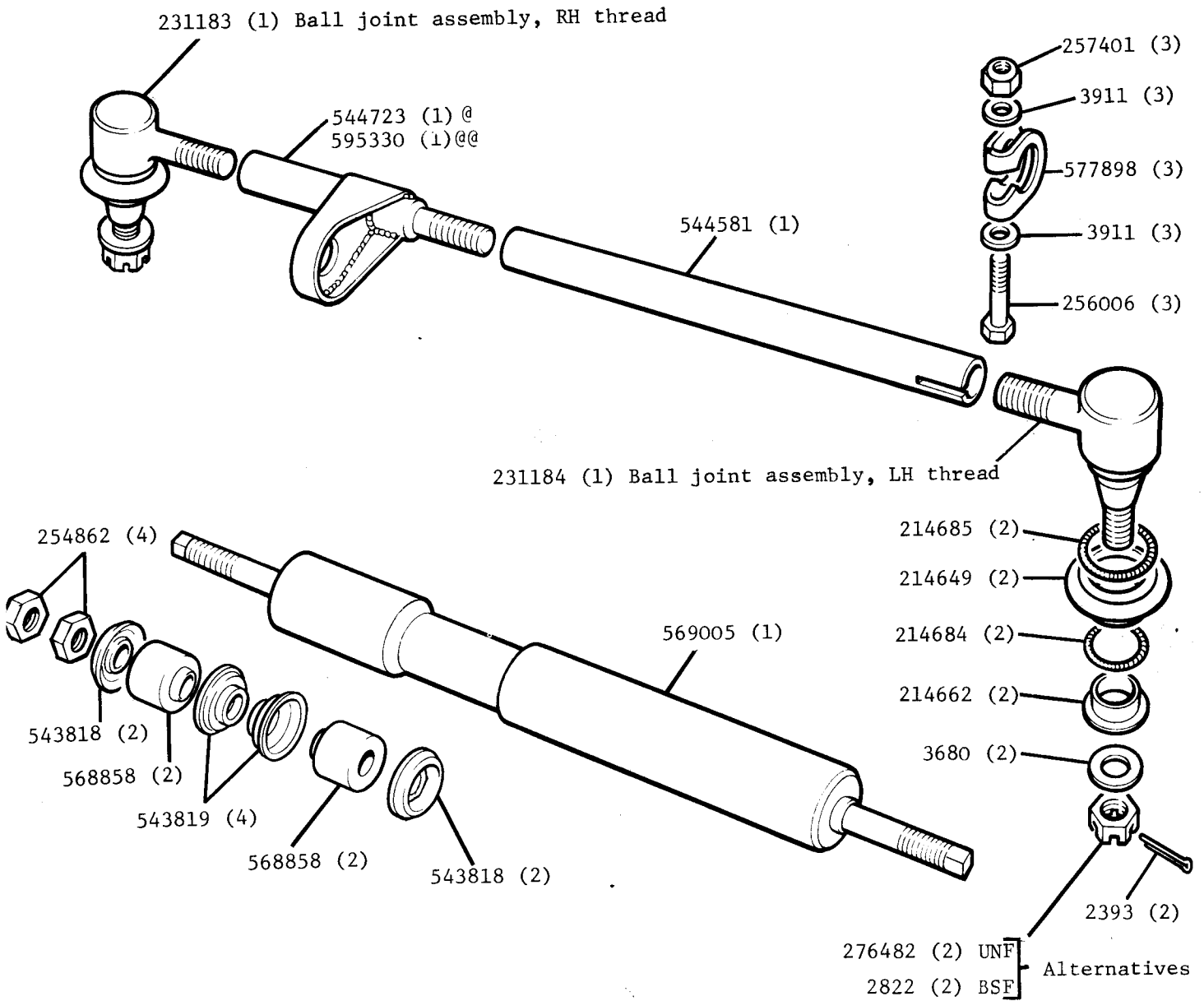

REMARKS

Steering Damper, Kit 605081 (1) @ Cannot be used in conjunction with extended shackles
608012 (1) @@

Drag link and damper bracket assembly 569719 (1) @
595331 (1) @@

@ Series 11A Land Rover

@@ Series 111 Land Rover

UNIVERSAL JOINT COVER PLATE SERIES IIA AND III

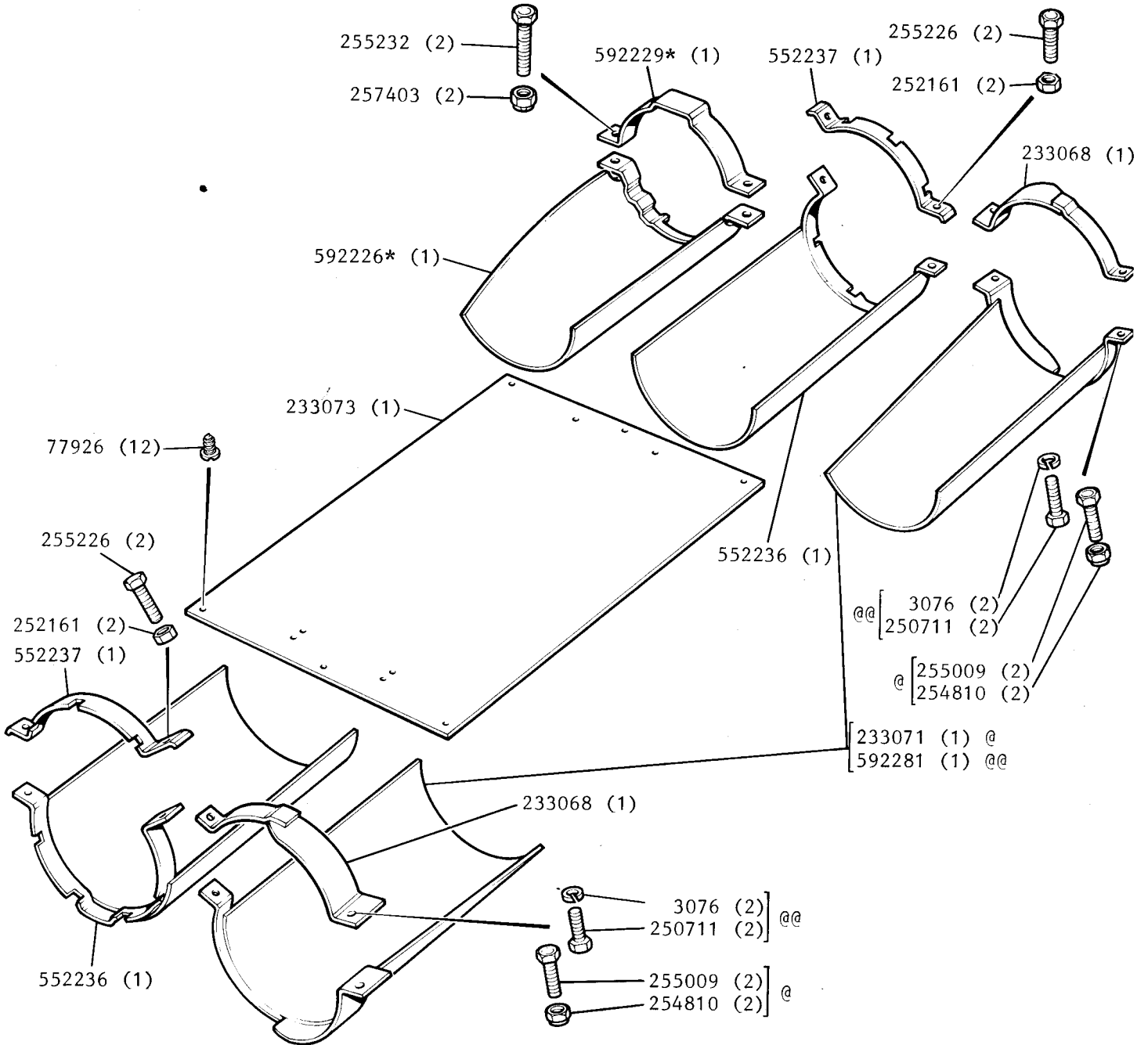

REMARKS

@ Cover fixed by strap. @@ Cover fixed to housing. † Universal Joint Cover Plate Kit.

- | | | |
|--|------|------------|
| † 261829 (1) 88" and 109" vehicles fitted with Rover axles front and rear |] @ | Series IIA |
| † 605930 (1) 109" vehicles fitted with an E.N.V. rear axle and Rover front axle | | |
| † 607301 (1) 109" vehicles fitted with an E.N.V rear axle and Rover front axle @@ | | |
| † 601989 (1) Series IIA 109" and Series III 1 ton vehicles fitted with E.N.V. axles front and rear | | |
| † 320821 (1) Series IIA and Series III 88" vehicles fitted with Rover axles front and rear |] @@ | |
| † 320822 (1) Series IIA 109" and Series III 109" vehicles fitted with Salisbury rear axle and Rover front axle | | |

HEAVY DUTY SHOCK ABSORBERS, SERIES IIA AND III

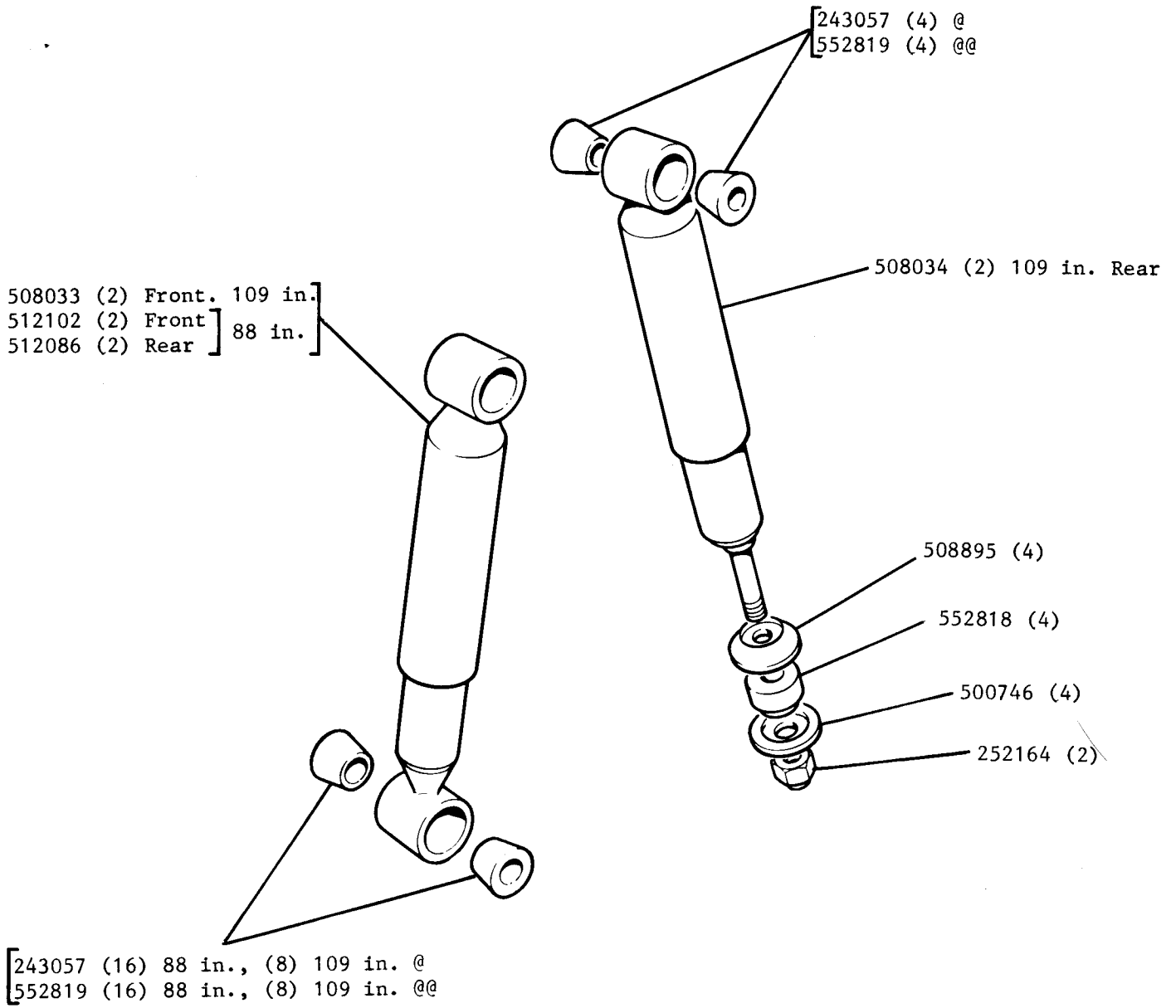

REMARKS

@ Except Angola January 1973 onwards

@@ Angola only January 1973 onwards

HEAVY DUTY ROAD SPRINGS, SERIES IIA AND III

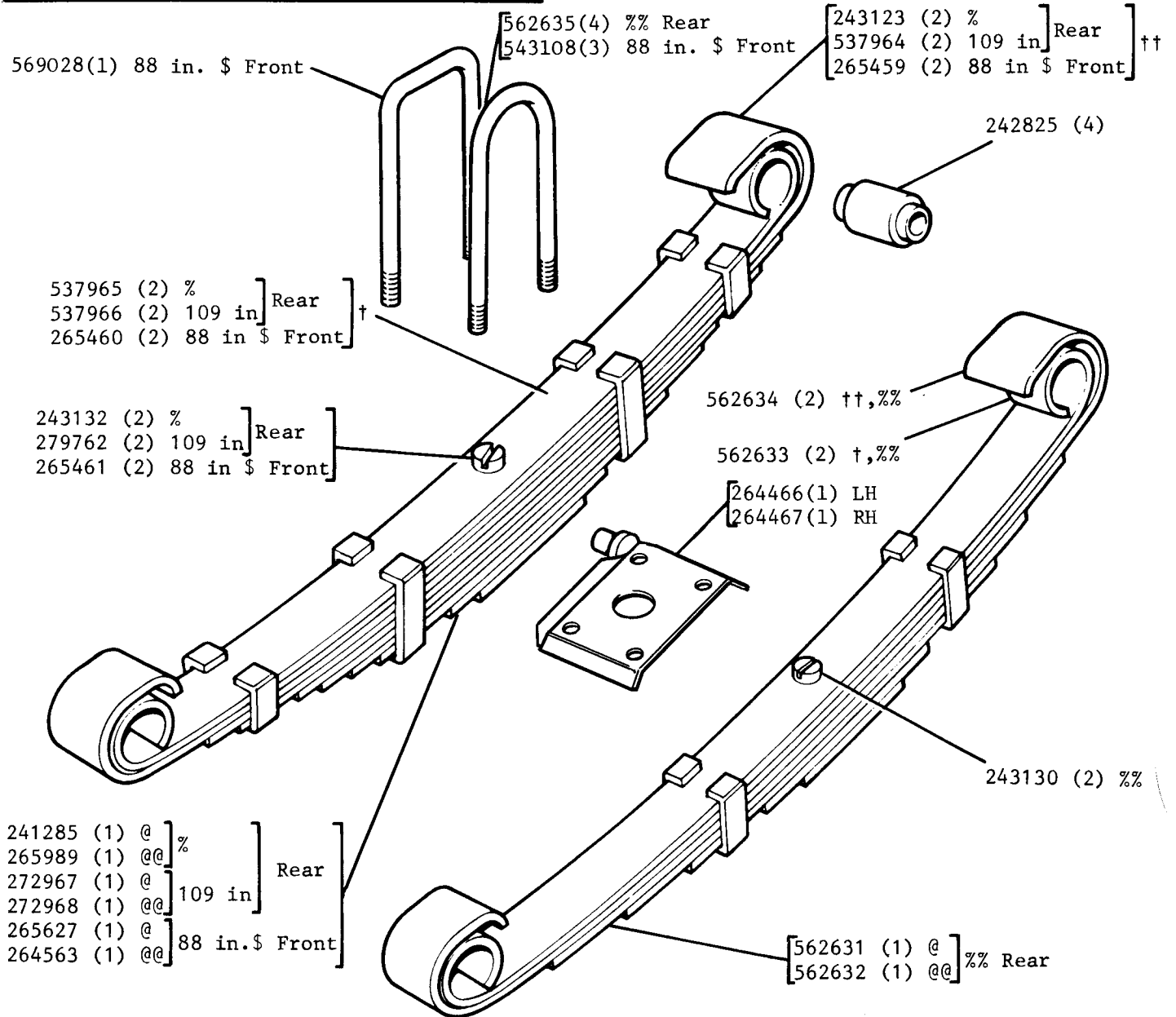

REMARKS

- @ Driver side spring assembly
- @@ Passenger side spring assembly
- † Main leaf
- †† Second leaf
- % Series IIA 88 in.
- %% Series III 88 in.
- \$ Used in conjunction with a hydraulic winch

BRAKE MASTER CYLINDER AND SERVO. SERIES III 109" 2½ LITRE MODELS

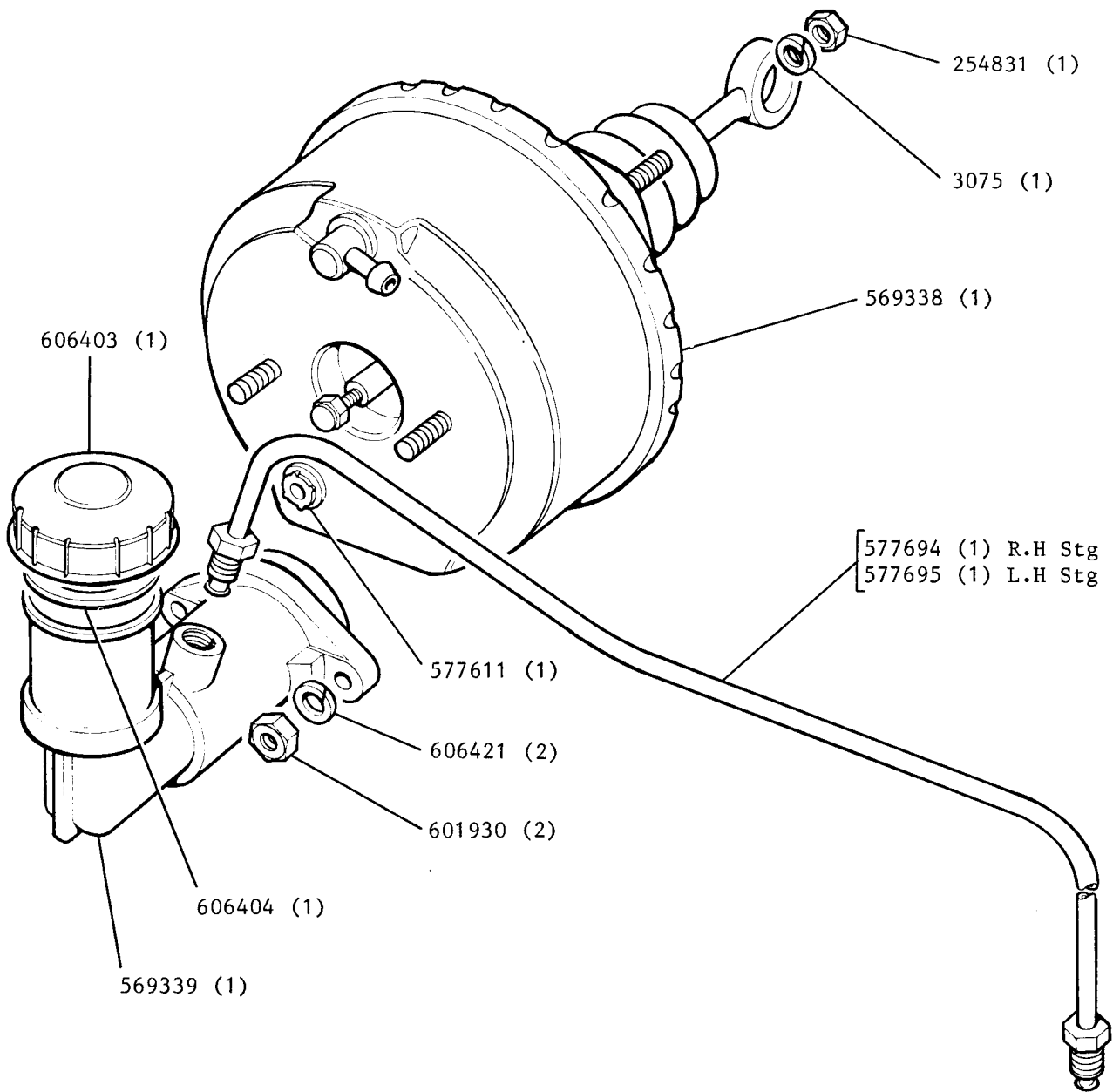

REMARKS

Brake Master Cylinder Overhaul Kit 606415 (1)

BRAKE PEDAL AND BRACKET, VEHICLES WITH SERVO

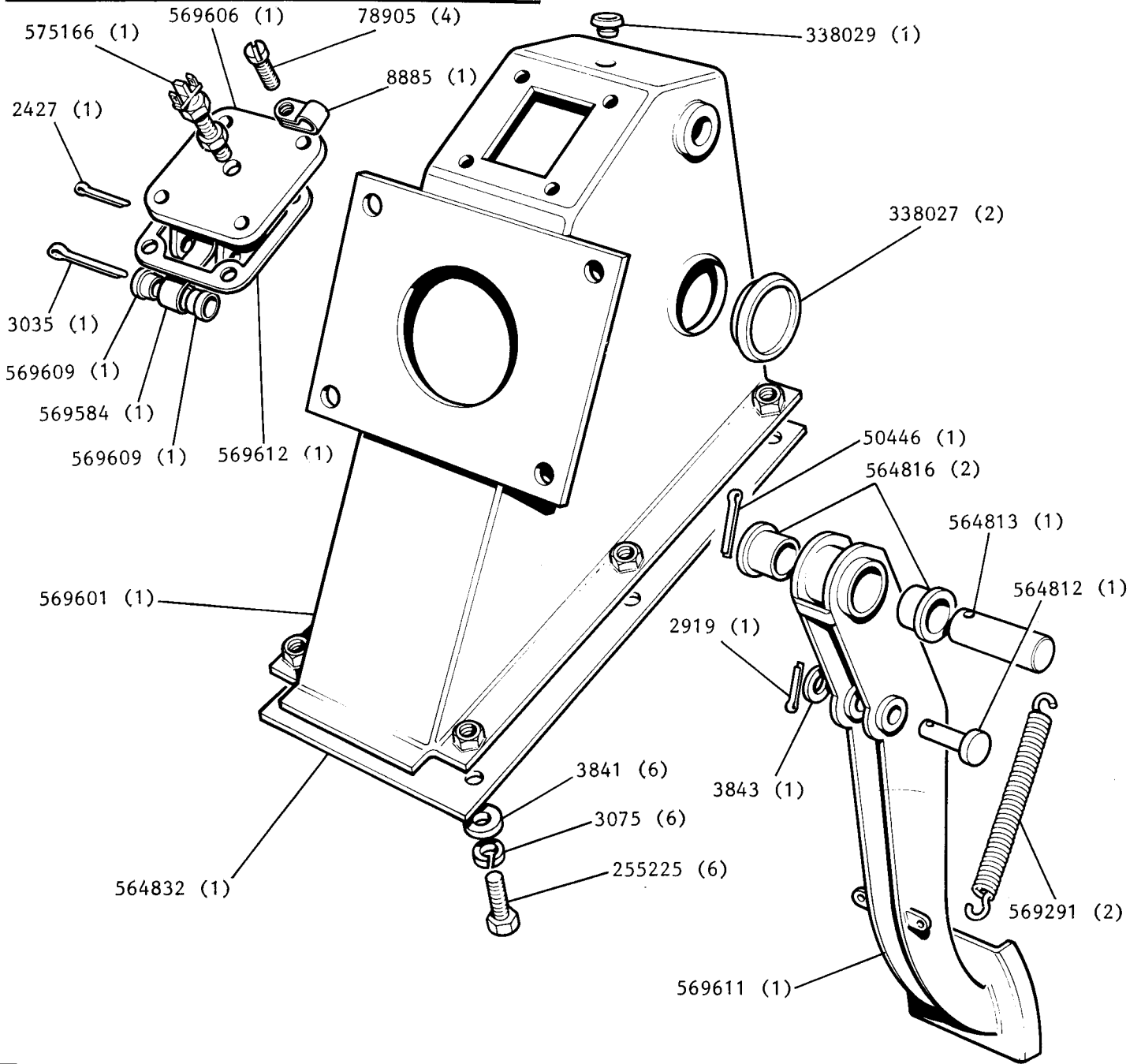

REMARKS

Brake pedal and bracket assembly 569652 (1)

BRAKE SERVO VACUUM SYSTEM THROTTLE BODY, INLET MANIFOLD AND OPERATING LEVERS. SERIES III DIESEL

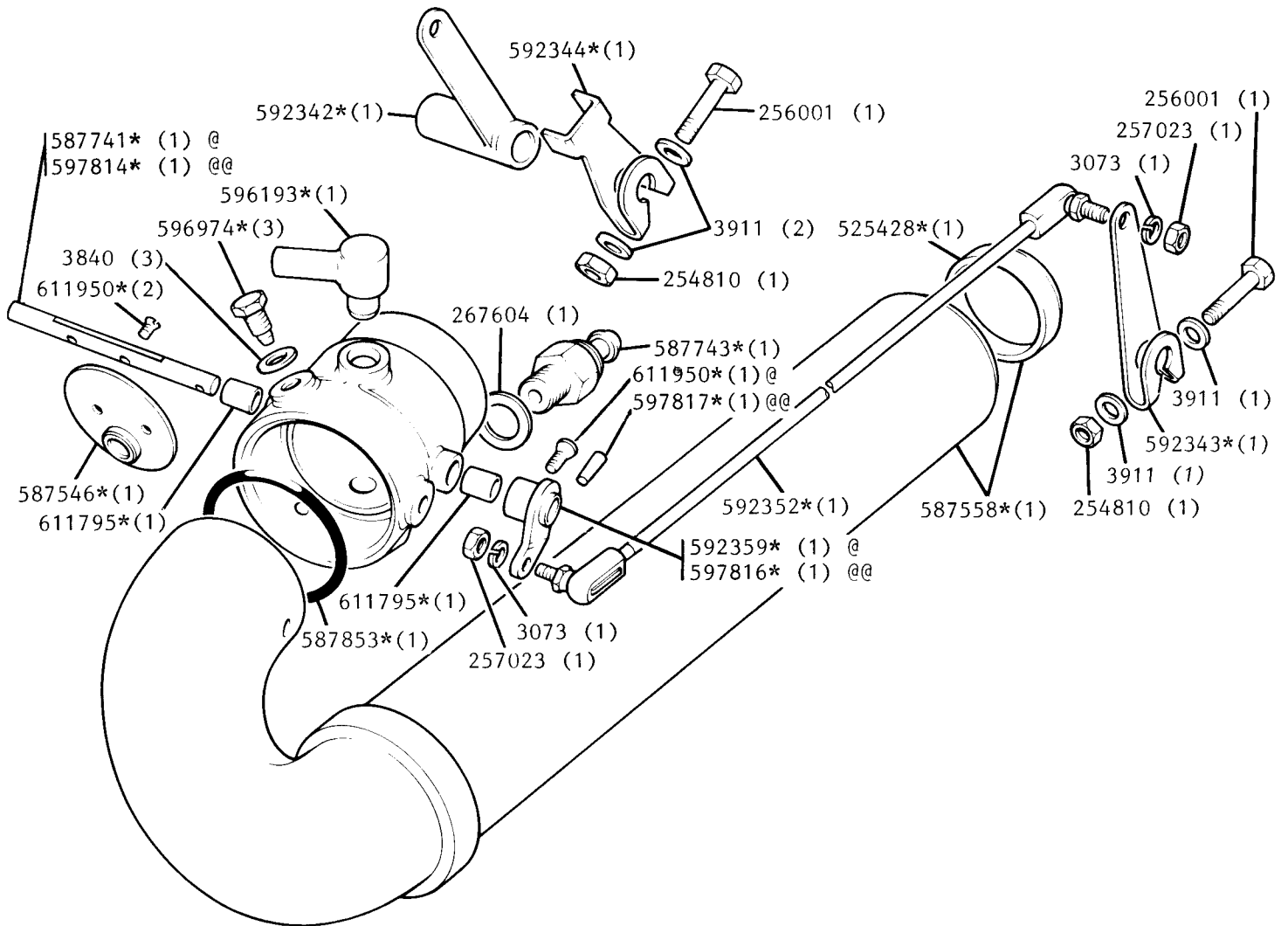

REMARKS

Throttle Body Complete Assembly 596253*(1) @
 Throttle Body Complete Assembly 597815* (1) @@
 @ Screw fixing
 @@ Taper pin fixing

**BRAKE SERVO VACUUM SYSTEM PIPES AND VACUUM TANK SERIES III
WITH VACUUM TANK MOUNTED ON L.H. FRONT WING VALANCE**

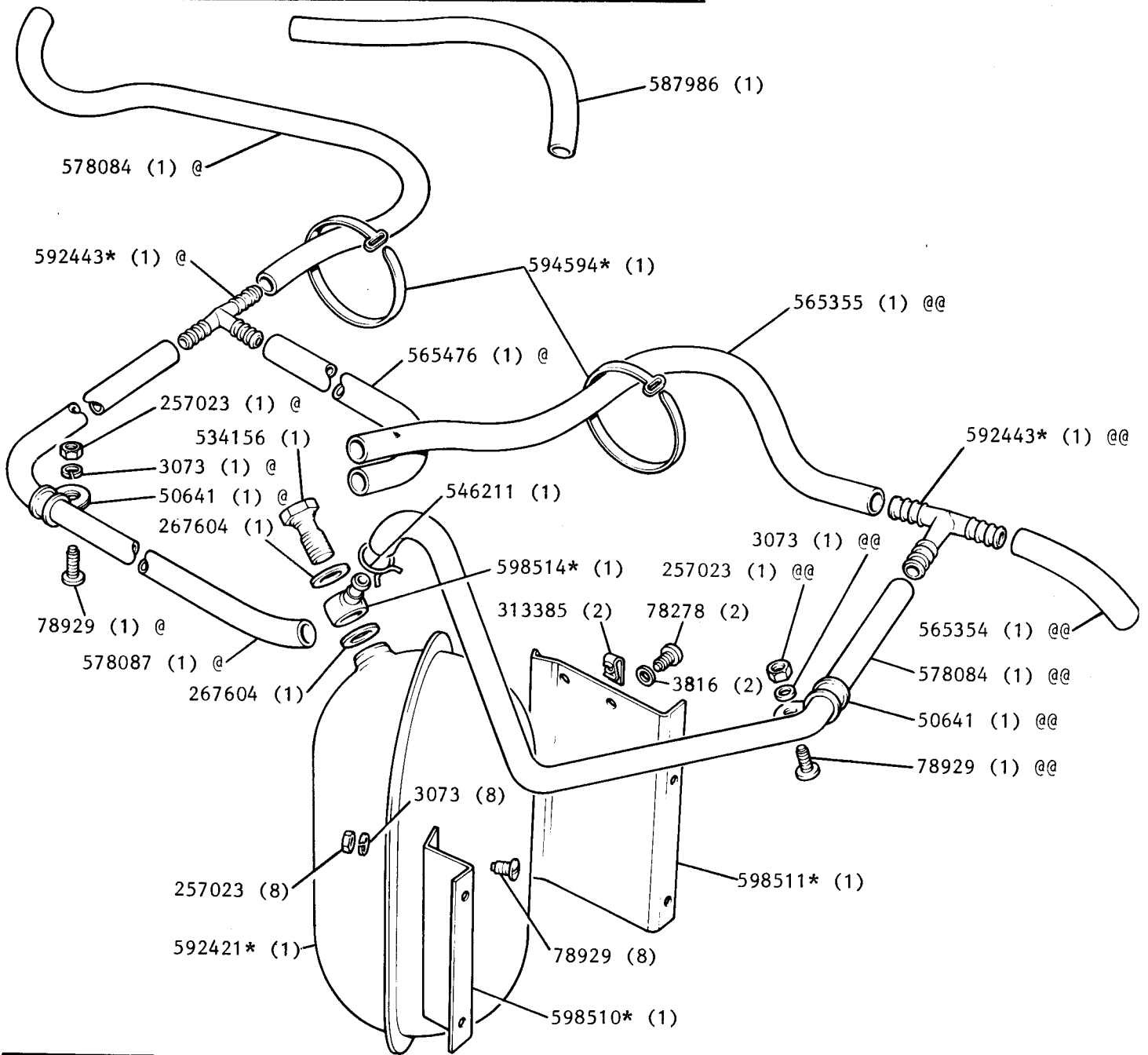

REMARKS

@ R.H. Stg
@@ L.H. Stg

VACUUM SYSTEM SERIES III PETROL MODELS

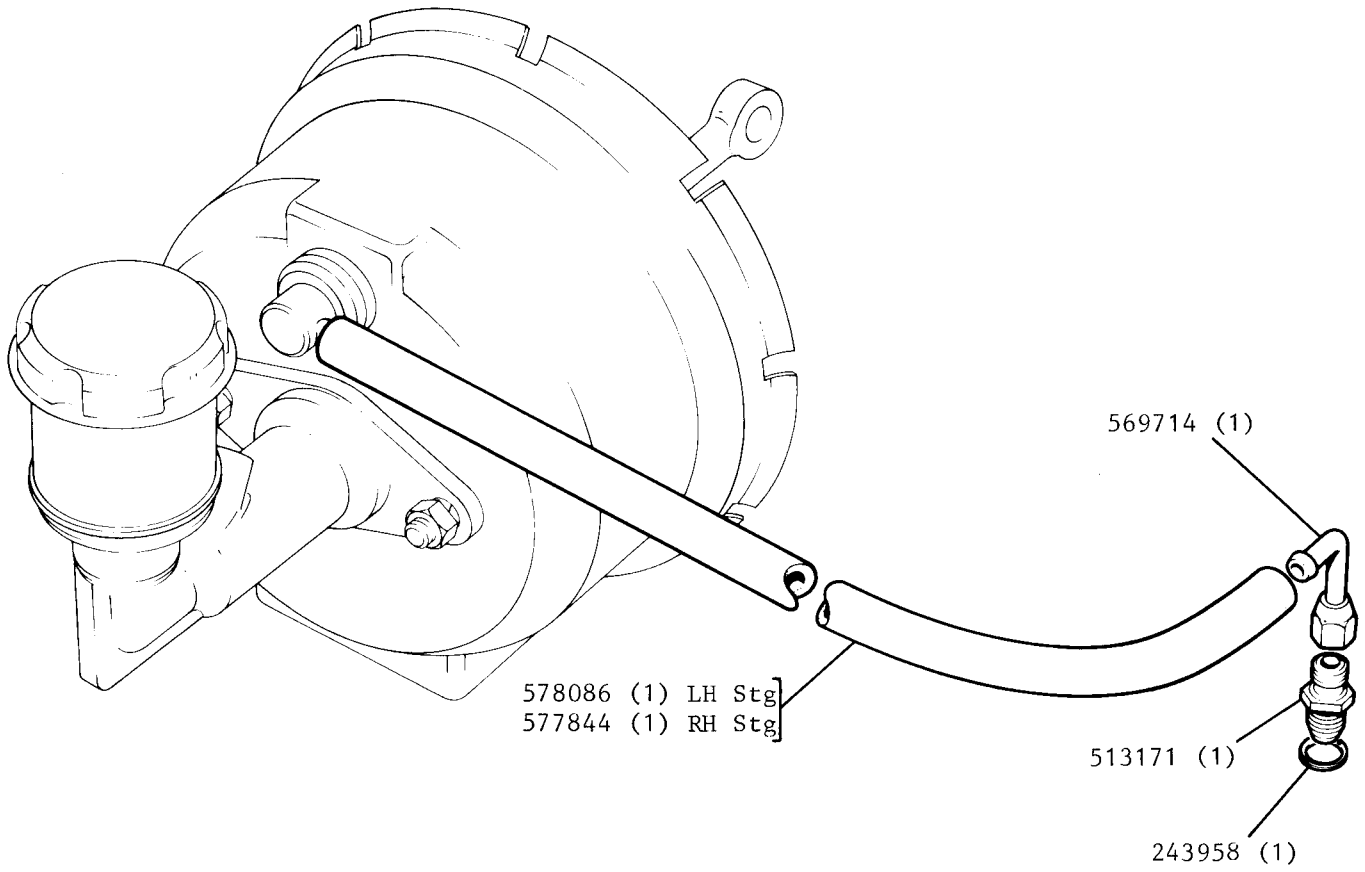

REMARKS

BRAKE VACUUM WARNING LOSS SERIES III 109 in.

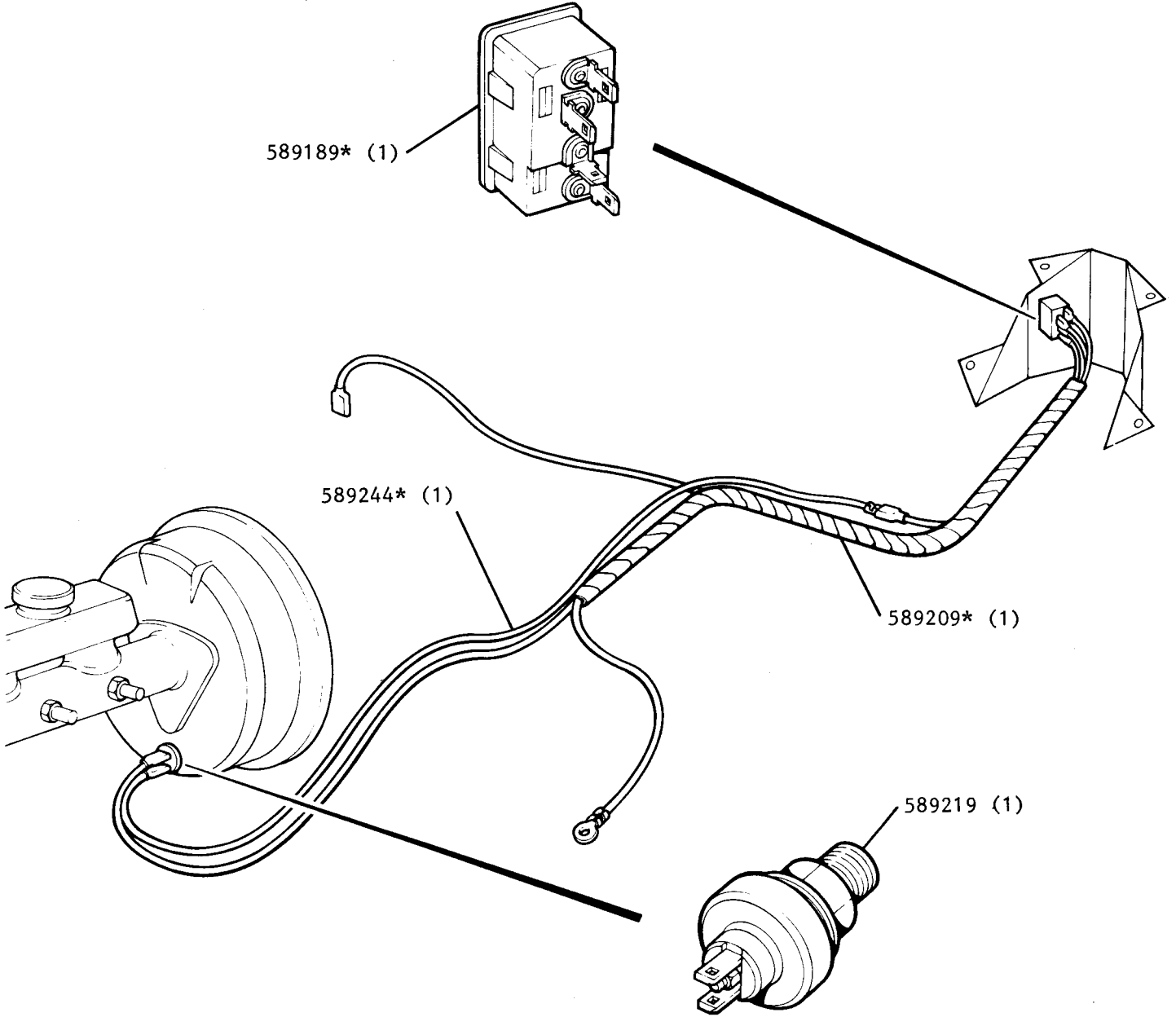

REMARKS

**TUBING, JETS, WIPER MOTOR, INSTRUMENT PANEL AND FIXINGS FOR TWO SPEED WIPER AND WASHER.
 SERIES IIA SWEDISH VEHICLES FROM VEHICLE SUFFIX G ONWARDS AND SERIES III**

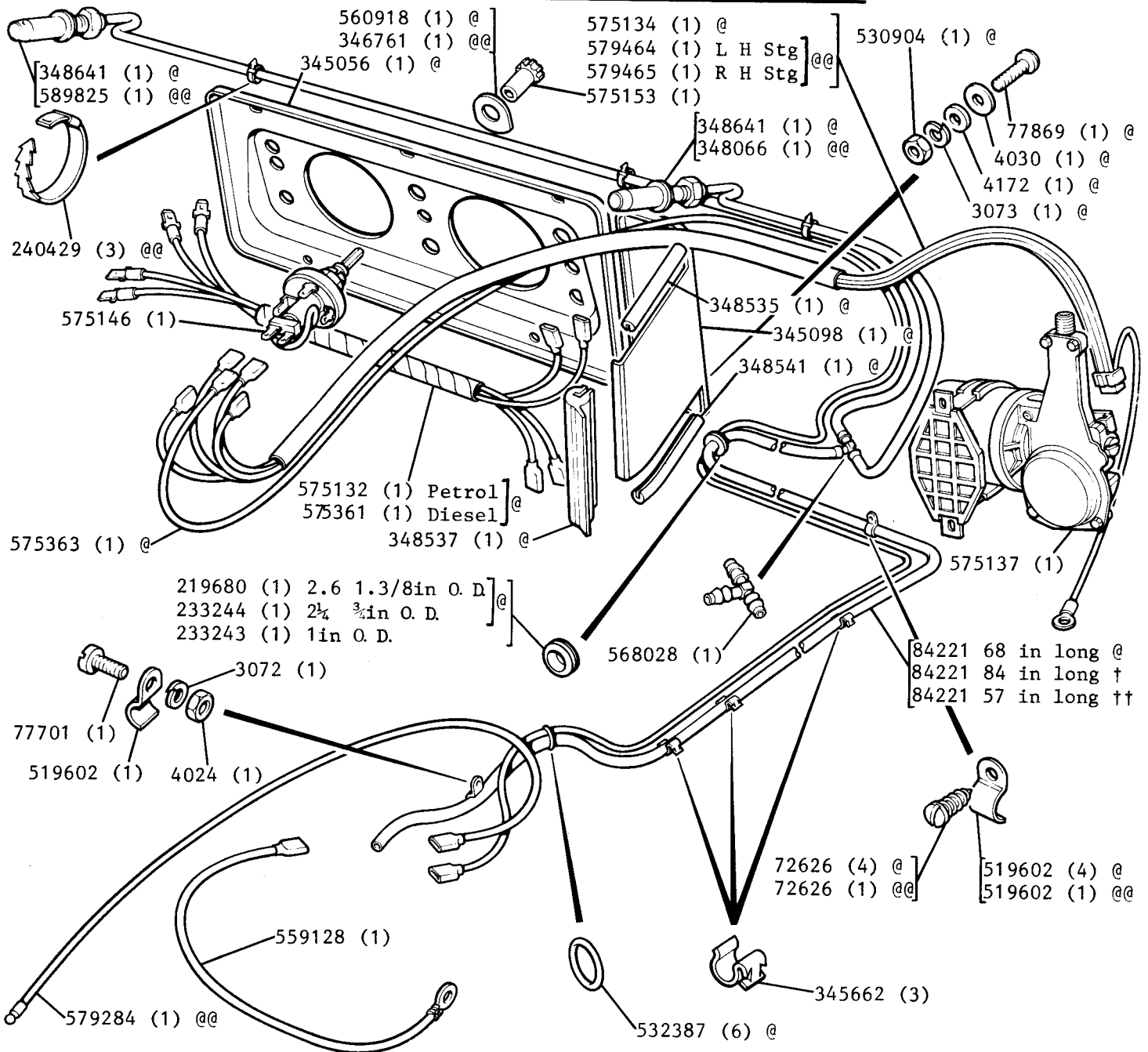

REMARKS

- @ Series IIA Swedish vehicles from vehicle suffix G onwards
- @@ Series III
- † Series III up to July 1972 inclusive
- †† From August 1972 onwards

TUBING, JETS AND FIXINGS FOR WINDSCREEN WASHER, ELECTRIC, SERIES IIA FROM JULY 1969 AND SERIES III.

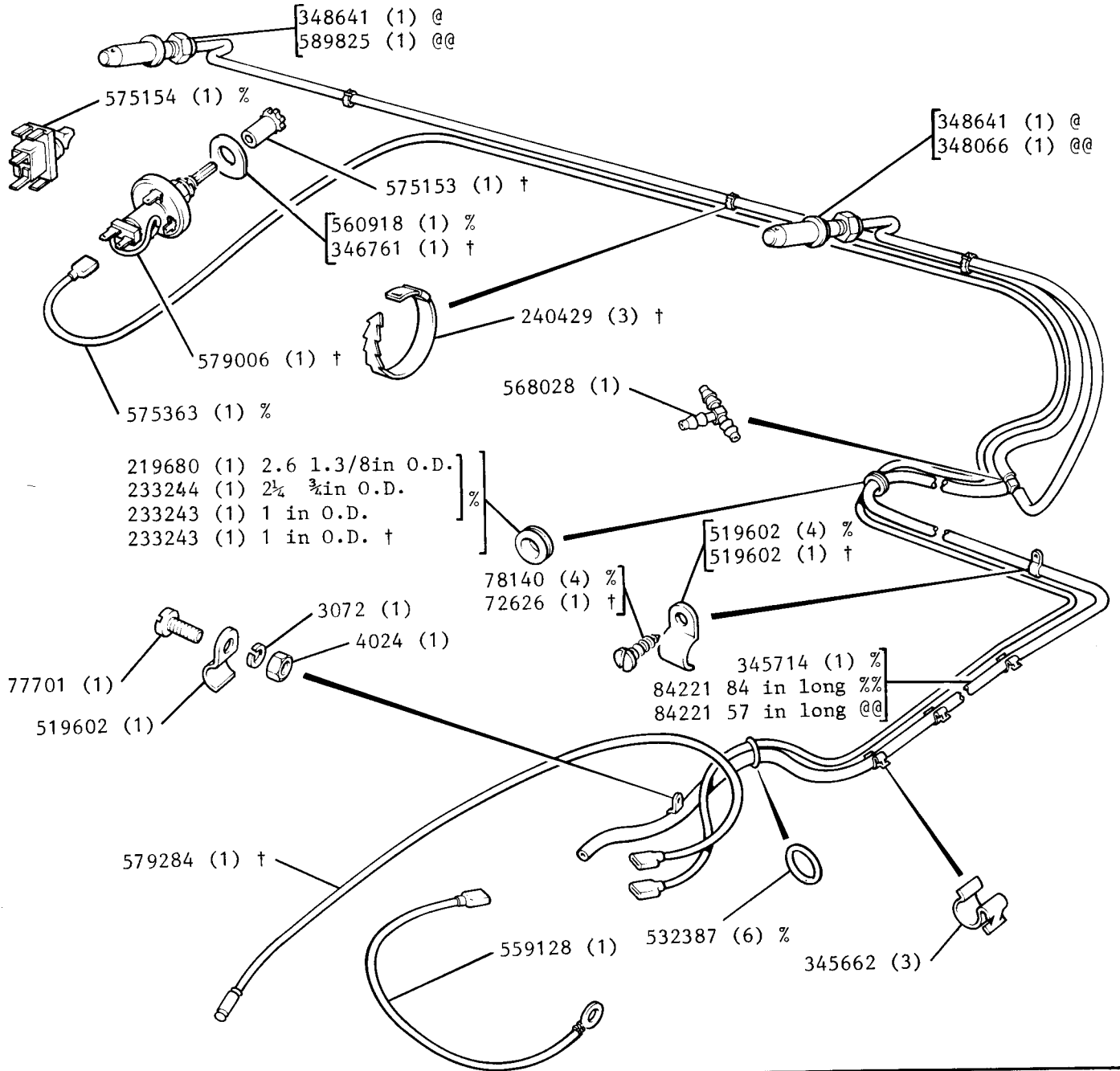

REMARKS

- @ Up to July 1972 inclusive
- @@ From August 1972 onwards
- % Series IIA
- %% Series III up to July 1972 inclusive
- † Series III

TUBING, JETS AND FIXINGS FOR WINDSCREEN WASHER MANUAL, SERIES IIA

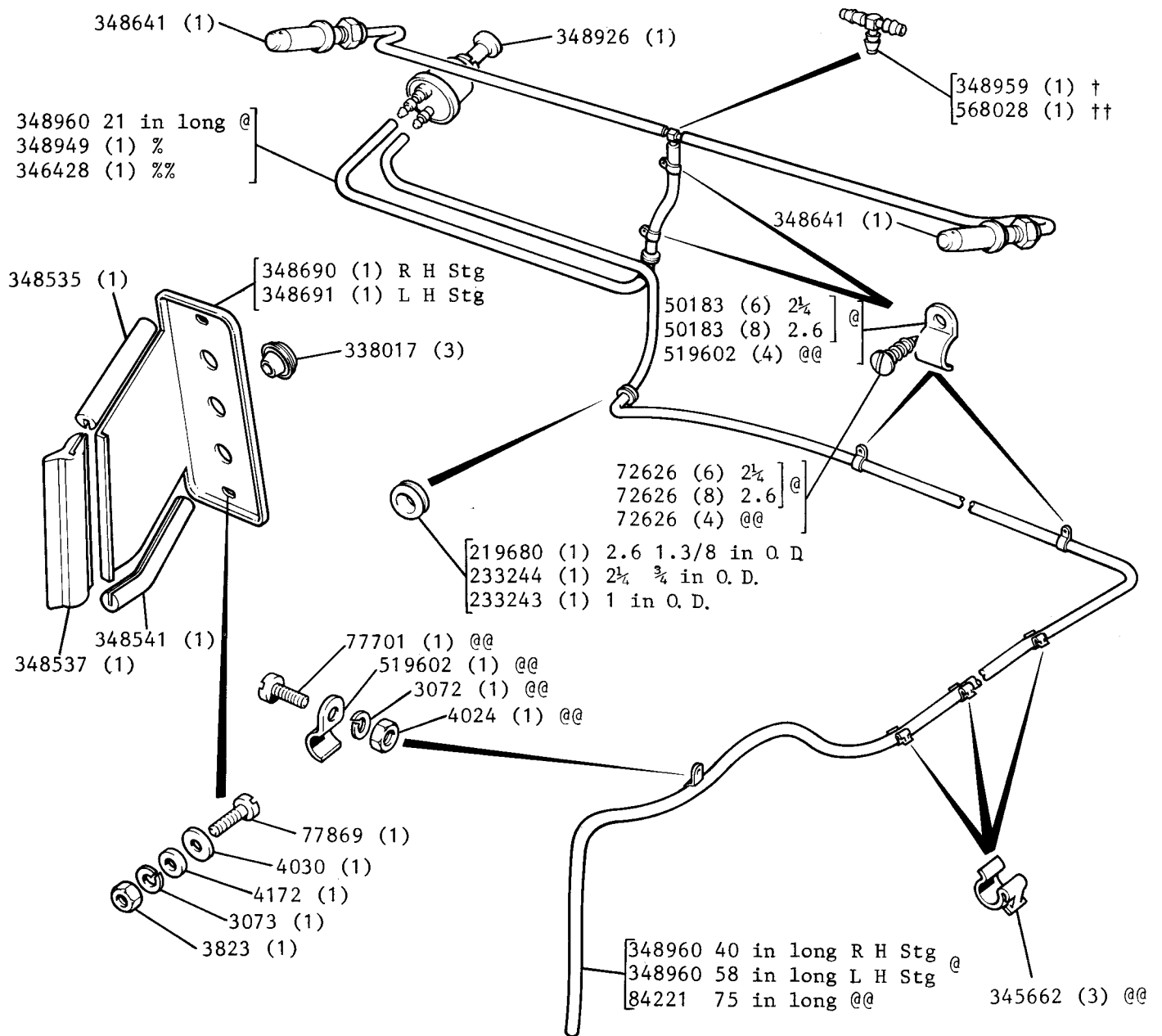

REMARKS

- † Three equal diameter outlets
- †† Two equal diameter outlets
- @ Up to vehicle suffix F inclusive
- @@ From vehicle suffix G onwards
- % From vehicle suffix G to 5th July 1970
- %% From 6th July 1970 onwards

WASHER BOTTLE FOR MANUAL SCREEN WASHER SERIES IIA

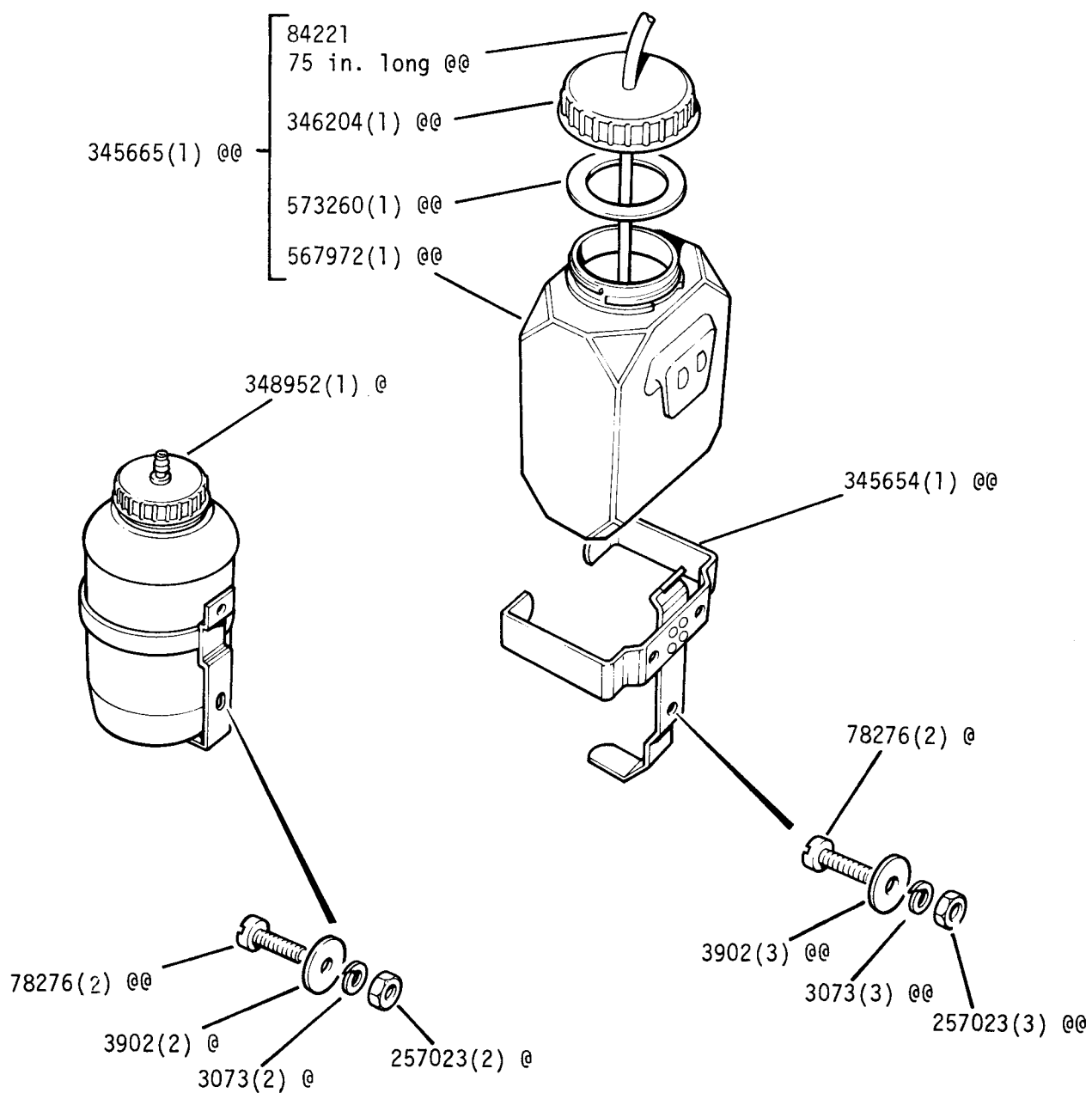

REMARKS

@ Up to vehicle suffix F inclusive
 @@ From vehicle suffix G onwards

WASHER BOTTLE AND PUMP FOR ELECTRIC SCREEN WASHER SERIES IIA AND III

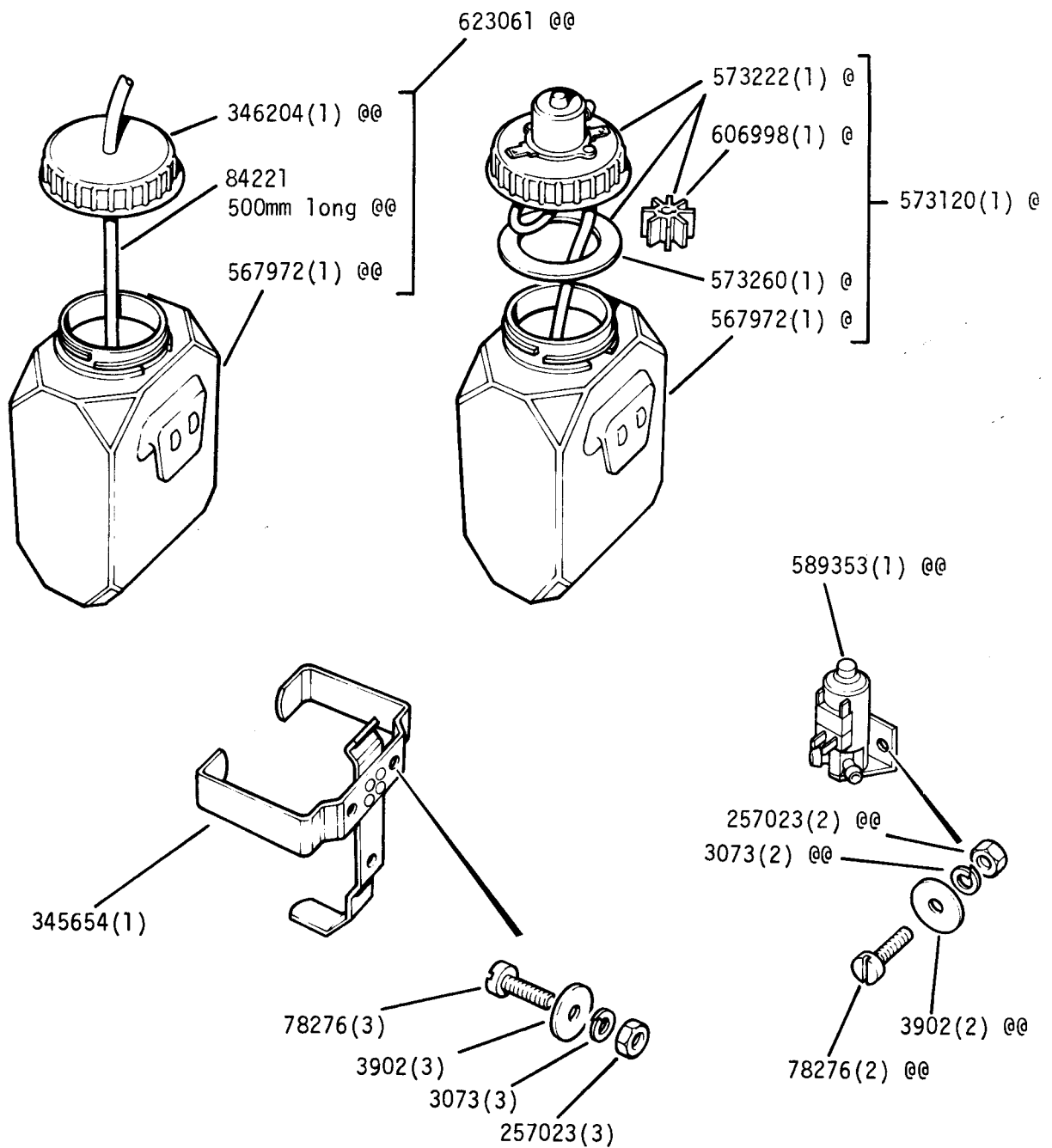

REMARKS

- @ Pump on washer bottle cap
- @@ Pump on LH wing valance

AUXILIARY INSTRUMENT PANEL SERIES IIA

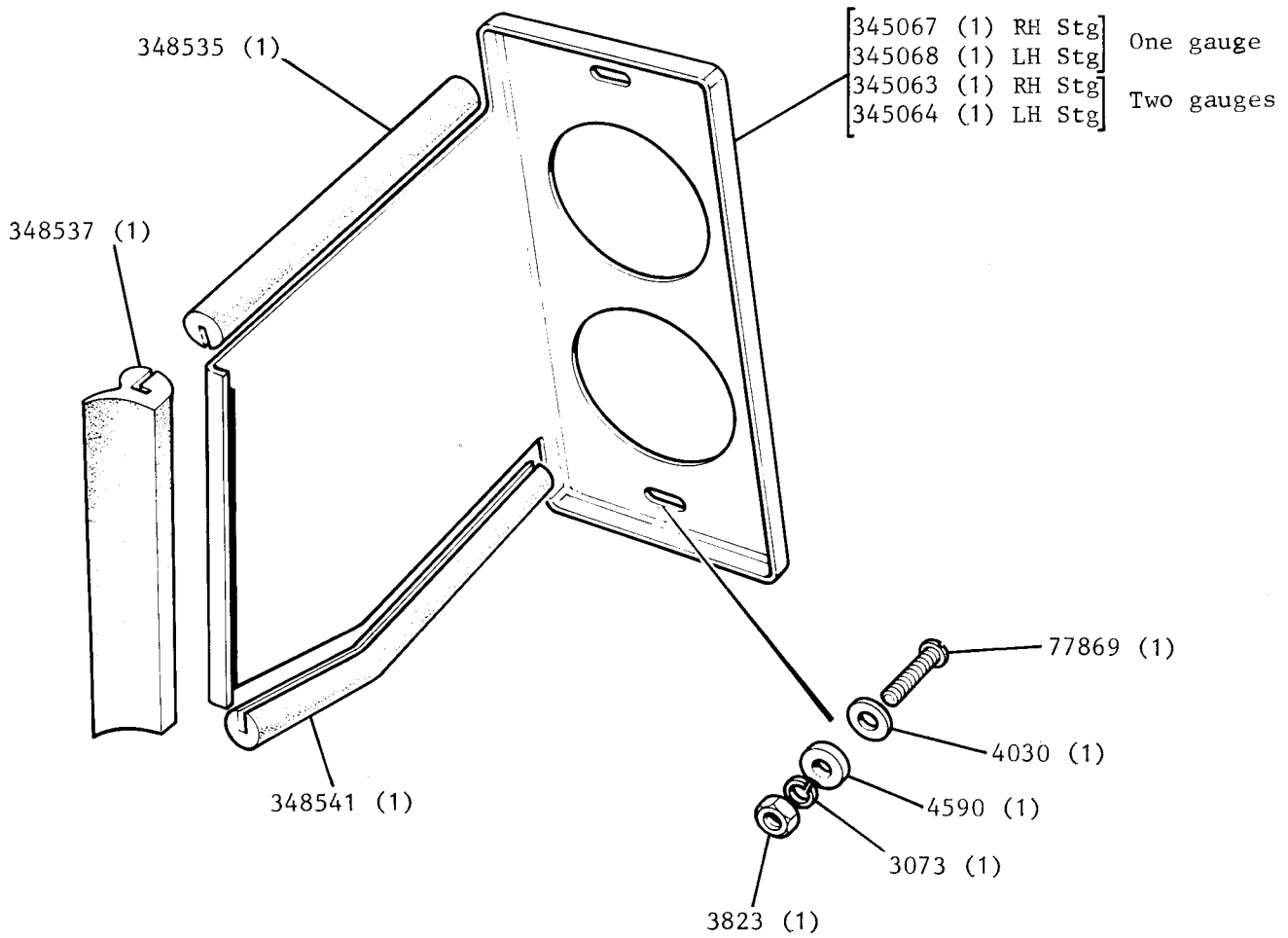

REMARKS

AUXILIARY SWITCH PANEL AND AUXILIARY INSTRUMENT COVER PANEL SERIES III

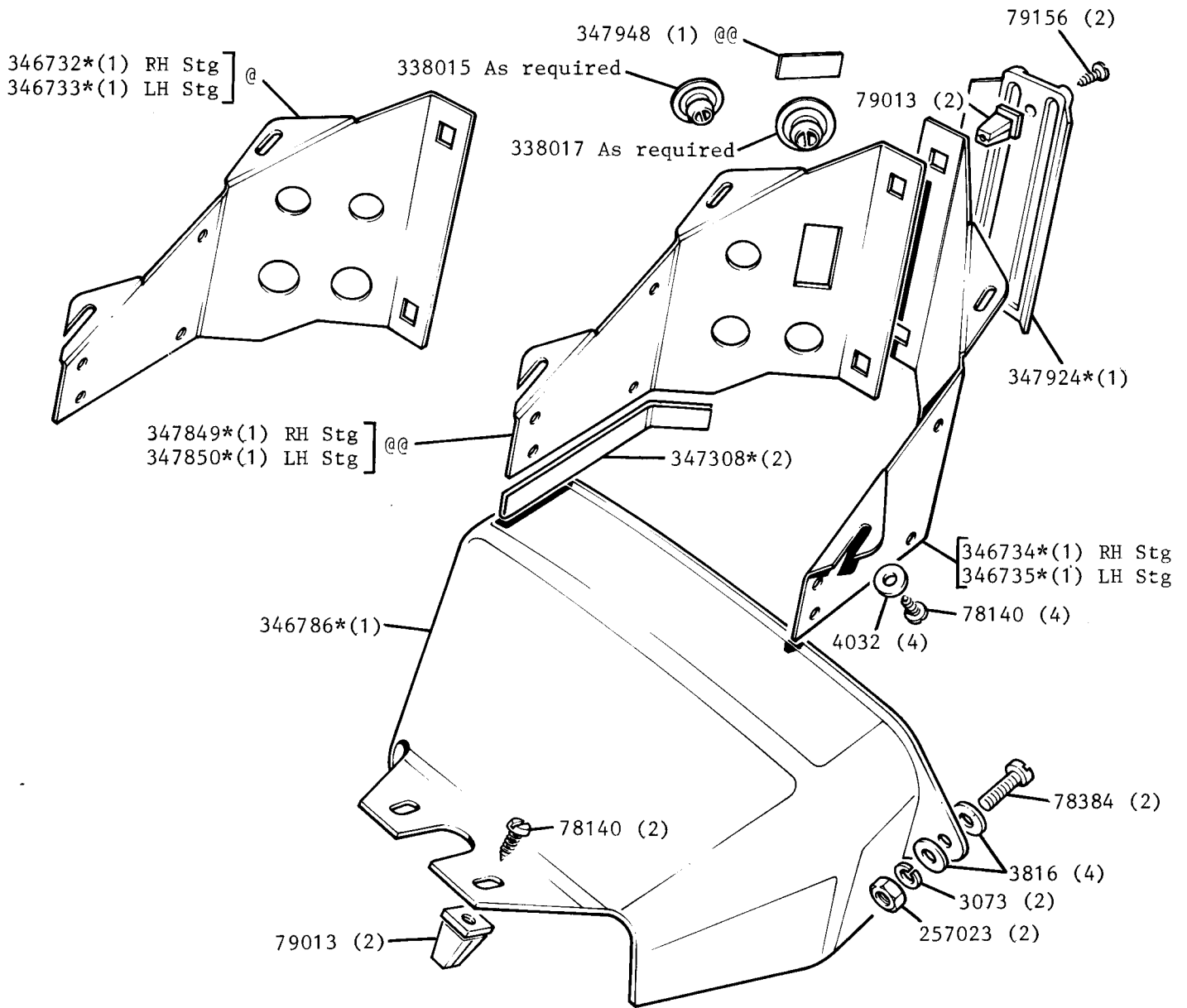

REMARKS

@ Part of Kits 320837*, 320838* only

@@ Part of Kits 320843*, 320844* only

Auxiliary Switch Panel Kit 320837*(1) RH Stg

Auxiliary Switch Panel Kit 320838*(1) LH Stg

Brake Failure Warning Light and Switch Panel Kit 320843*(1) RH Stg

Brake Failure Warning Light and Switch Panel Kit 320844*(1) LH Stg

Cover Panel Kit 320835*(1)

Use in conjunction with kits 320840*, 320841*, 320865* or 320866 when provision for an extra gauge is required

AUXILIARY SWITCH AND INSTRUMENT PANEL SERIES III

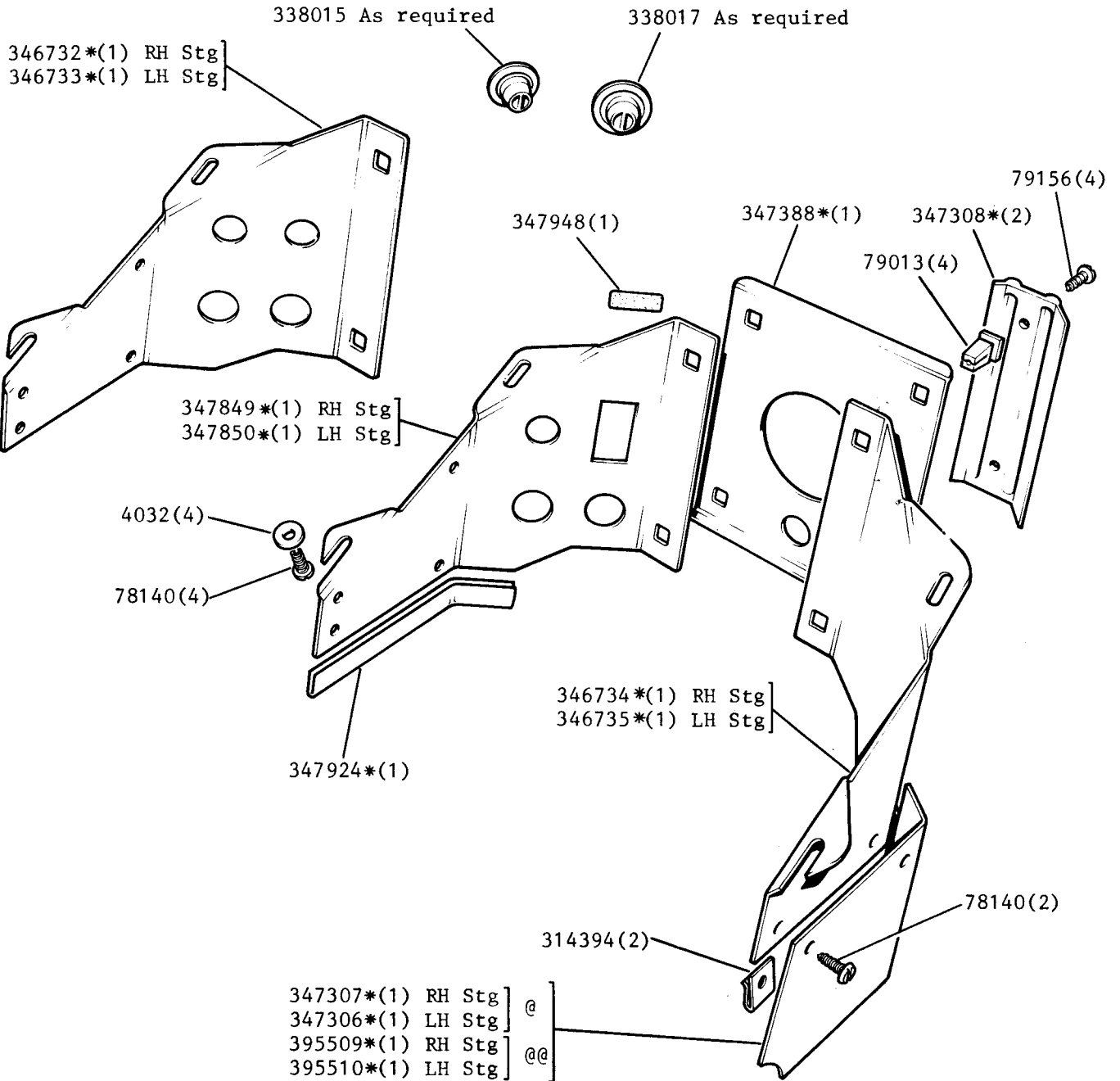

REMARKS

@ Up to June 1972 inclusive
 @@ From July 1972 onwards

- Auxiliary Instrument Panel Kit 320840*(1) RH Stg] @
- Auxiliary Instrument Panel Kit 320841*(1) LH Stg] @
- Auxiliary Instrument Panel Kit 320865*(1) RH Stg] @@
- Auxiliary Instrument Panel Kit 320866*(1) LH Stg] @@

Must be used
 in conjunction
 with one of the
 following kits.
 320837, 320838,
 320843 and 320844

SPEEDOMETERS. SERIES IIA AND III

579468 (1) \$

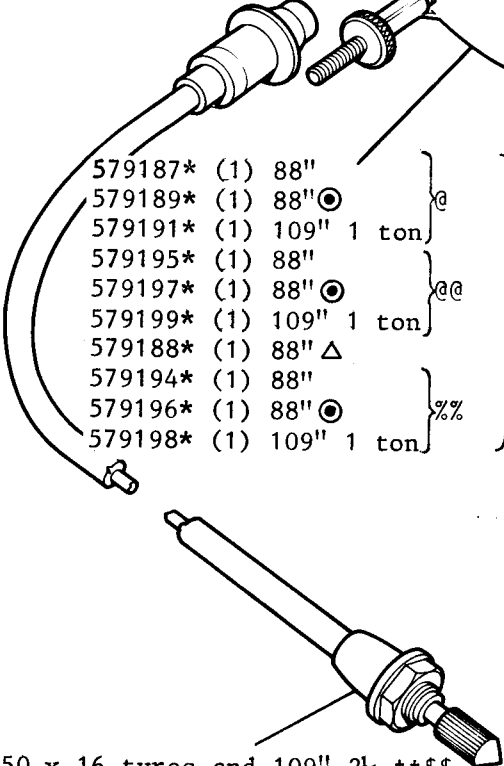
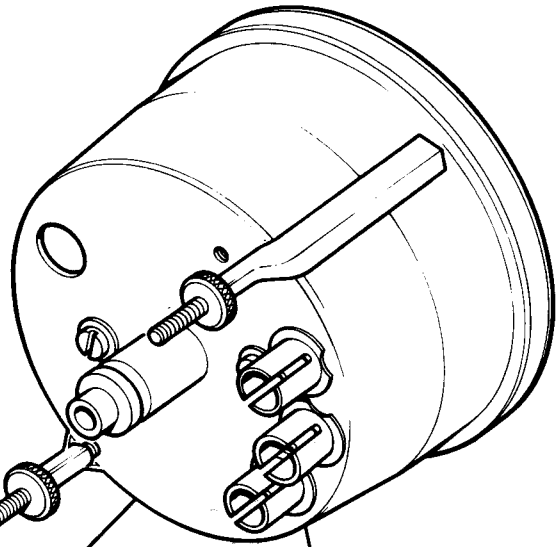
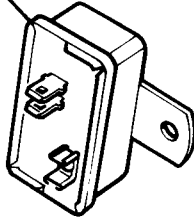
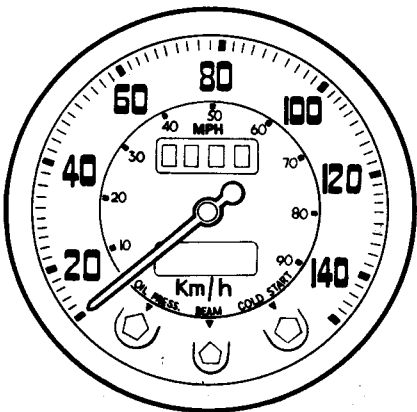
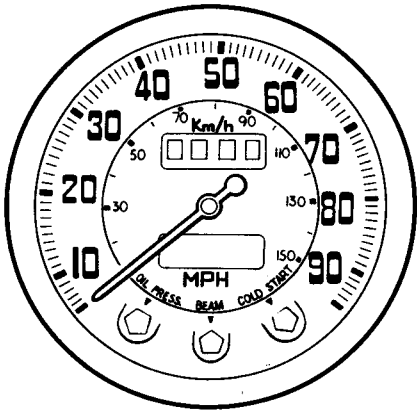

- 579187* (1) 88" } @
- 579189* (1) 88" ⊙ } @
- 579191* (1) 109" 1 ton } @
- 579195* (1) 88" } @@
- 579197* (1) 88" ⊙ } @@
- 579199* (1) 109" 1 ton } @@
- 579188* (1) 88" Δ } %
- 579194* (1) 88" } %
- 579196* (1) 88" ⊙ } %
- 579198* (1) 109" 1 ton } %

- \$ 239565 (1) 88" } @
- 279341 (1) 88" ⊕ } @
- 240427 (1) 88" } @@
- 279343 (1) 88" ⊕ } @@ †
- 279340 (1) 88" Δ } †
- 240426 (1) 88" } %
- 279342 (1) 88" ⊕ } %
- 540115 (1) 88" } @
- 540118 (1) 88" ⊕ } @
- 540133 (1) 88" } @@ ††
- 540134 (1) 88" ⊕ } @@ ††
- 540117 (1) 88" Δ } ††
- 540129 (1) 88" } %
- 540130 (1) 88" ⊕ } %
- 559160 (1) @ } \$
- 559165 (1) @@ } 109" 2.6
- 559164 (1) % } \$

540128 (1) 88", 88" fitted with 750 x 16 tyres and 109" 2¼ ††\$
 579172* (1) \$

REMARKS

- \$ Series III
- \$\$ Series IIA
- † Up to vehicle suffix C inclusive
- †† From vehicle suffix D onwards
- @ K.P.H. no trip
- @@ K.P.H. with trip
- % M.P.H. no trip
- %% M.P.H. with trip

- Δ Fitted with 750 x 16 tyres %
- ⊙ Fitted with 750 x 16 tyres and 109"
- ⊕ Fitted with 750 x 16 tyres and 109" 2¼